

クイック継手スマートタイプ

ストレート

●ATS



(1袋10個入り)
※φ16チューブ用は1袋5個入り

チューブサイズ
4
6
8
10
12
16

六角穴付ストレート

●ATSH



(1袋10個入り)
※φ16チューブ用は1袋5個入り

チューブサイズ
4
6
8
10
12
16

めすストレート

●ATSM



(1袋10個入り)

チューブサイズ
4
6
8
10
12

隔壁ユニオン

●AUK



本体：アルミ（黒アルマイト）
ナット：軟鋼（亜鉛めっき）

(1袋10個入り)

チューブサイズ
4
6
8
10
12

めす隔壁ユニオン

●AUKM



ナット：軟鋼（亜鉛めっき）

(1袋10個入り)

チューブサイズ
4
6
8
10
12

エルボ

●ATL



(1袋10個入り)

チューブサイズ
4
6
8
10
12

ロングエルボ

●ATLL



(1袋10個入り)

チューブサイズ
4
6
8
10
12

ティ

●ATT



(1袋10個入り)

チューブサイズ
4
6
8
10
12

ブランチティ

●ATB



(1袋10個入り)

チューブサイズ
4
6
8
10
12

ブランチワイ

●ATBY



(1袋10個入り)

チューブサイズ
4
6
8
10
12

ブランチエルボワイ

●ATBLY



(1袋10個入り)

チューブサイズ
4
6
8
10
12

ブランチ2重ワイ

●ATBW



(1袋10個入り)

チューブサイズ
4
6

クイック継手スマートタイプ

ブランチトリプル

●ATBE



(1袋10個入り)

チューブサイズ

6-4
8-4
8-6
10-8

ブランチトリプルダブル

●ATBEW



(1袋10個入り)

チューブサイズ

8-4
8-6
10-6
10-8

ブランチテトラ

●ATBZ



(1袋10個入り)

チューブサイズ

4
6
8
10
12

隔壁レデューサ

●ASKR



(1袋1個入り)

チューブサイズ

4
6
8
10
12

●ATS



(1袋10個入り)
※φ16チューブ用は1袋5個入り

チューブサイズ
4
6
8
10
12
16

注文記号

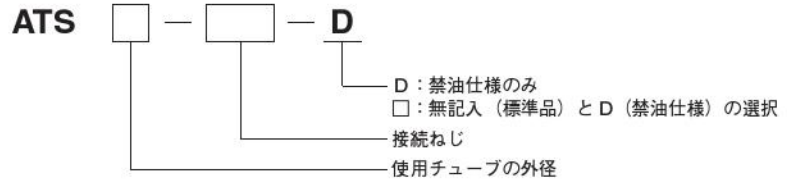

寸法図 (mm)

ストレート
ATS

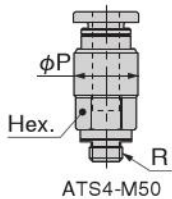
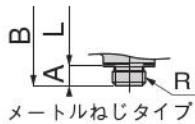
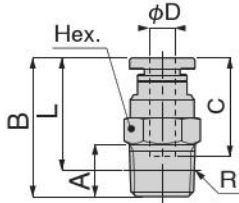

形式	チューブ外径 φD	R	A	B	L	C	対辺 Hex.	φP	オリフィス径 (φmm)	質量 (g)
ATS4-M5-D	4	M5×0.8	2.8	19.8	17	14.9	10	—	2.4	5.6
ATS4-M50-□	4	M5×0.8	2.8	22.7	19.9	14.9	8	9.7	2.4	6.1
ATS4-M6-D	4	M6×1	3.8	20.8	17	14.9	10	—	3	6.0
ATS4-01-D	4	R1/8	8	21	17	14.9	10	—	3	7.4
ATS4-02-□	4	R1/4	11	22.5	16.5	14.9	14	—	3	16
ATS6-M5-D	6	M5×0.8	2.8	21.9	19.1	17	12	—	2.4	8.1
ATS6-M6-D	6	M6×1	3.8	22.9	19.1	17	12	—	3	8.5
ATS6-01-D	6	R1/8	8	22.3	18.3	17	12	—	5	8.2
ATS6-02-□	6	R1/4	11	23.7	17.6	17	14	—	5	15
ATS6-03-□	6	R3/8	12	24.5	18.1	17	17	—	5	28
ATS8-01-□	8	R1/8	8	27.9	23.9	18.2	14	—	6	14
ATS8-02-□	8	R1/4	11	26.6	20.6	18.2	14	—	7	14
ATS8-03-□	8	R3/8	12	25.5	19.2	18.2	17	—	7	25
ATS10-01-□	10	R1/8	8	30.3	26.3	20.7	17	—	6	21
ATS10-02-□	10	R1/4	11	29.8	23.8	20.7	17	—	8.5	19
ATS10-03-□	10	R3/8	12	29.3	23	20.7	17	—	9	24
ATS10-04-□	10	R1/2	15	30.4	22.2	20.7	21	—	9	46
ATS12-02-□	12	R1/4	11	35.9	29.9	23.3	21	—	8.5	37
ATS12-03-□	12	R3/8	12	31.9	25.6	23.3	21	—	11	30
ATS12-04-□	12	R1/2	15	33.9	25.7	23.3	21	—	11	44
ATS16-03-□	16	R3/8	12	39.3	33	24.8	24	—	11	54
ATS16-04-□	16	R1/2	15	41.3	33.1	24.8	24	—	13	63

*D⇒禁油仕様のみ、-□⇒無記入 (標準品) と D (禁油仕様) の選択
*テーパねじタイプのL寸法は、ねじ締付け後の参考寸法です。

六角穴付ストレート

●ATSH



チューブサイズ
4
6
8
10
12
16

(1袋10個入り)
※φ16チューブ用は1袋5個入り

注文記号

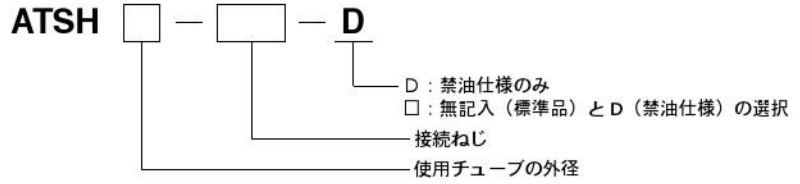

寸法図 (mm)

六角穴付ストレート
ATSH

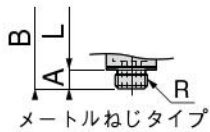
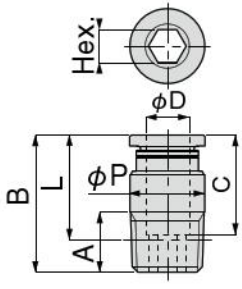

形式	チューブ外径 φD	R	A	B	L	C	対辺 Hex.	φP	オリフィス径 (φmm)	質量 (g)
ATSH4-M5-D	4	M5×0.8	2.8	19.7	16.9	14.9	2.5	9.7	2.6	4.6
ATSH4-M6-D	4	M6×1	3.8	20.7	16.9	14.9	2.5*	9.7	2.6*	5.4
ATSH4-01-D	4	R1/8	8	20	16	14.9	2.5	9.7	2.6	6.6
ATSH6-M5-D	6	M5×0.8	2.8	21.3	18.5	17	2.5	11.8	2.6	5.6
ATSH6-M6-D	6	M6×1	3.8	22.3	18.5	17	3	11.8	3.2	6.3
ATSH6-01-D	6	R1/8	8	22.1	18.1	17	4	11.8	4.2	7.6
ATSH6-02-□	6	R1/4	11	21.3	15.2	17	4	13.7	4.2	13
ATSH8-01-□	8	R1/8	8	25.9	21.9	18.2	5	13.7	5.3	8.8
ATSH8-02-□	8	R1/4	11	25.1	19.1	18.2	6	13.7	6.3	13
ATSH8-03-□	8	R3/8	12	22.2	15.9	18.2	6	16.8	6.3	19
ATSH10-01-□	10	R1/8	8	30.3	26.3	20.7	5	17.5	5.3	17
ATSH10-02-□	10	R1/4	11	29.8	23.8	20.7	6	17.5	6.3	20
ATSH10-03-□	10	R3/8	12	29.3	23	20.7	6	17.5	6.3	26
ATSH10-04-□	10	R1/2	15	30.3	22.1	20.7	6	20.8	6.3	45
ATSH12-02-□	12	R1/4	11	35.9	29.9	23.3	6	20.8	6.3	29
ATSH12-03-□	12	R3/8	12	31.9	25.6	23.3	8	20.8	8.4	31
ATSH12-04-□	12	R1/2	15	33.9	25.7	23.3	8	20.8	8.4	45
ATSH16-03-□	16	R3/8	12	39.3	33	24.8	10	26	10.5	61
ATSH16-04-□	16	R1/2	15	40.3	32.1	24.8	12	26	12.6	65

※六角レンチ干渉によるロック爪不具合を改善するため、内径六角対辺を見直し、オリフィス径が変更になりました。

*D⇒禁油仕様のみ、-□⇒無記入 (標準品) と D (禁油仕様) の選択

*テーパねじタイプのL寸法は、ねじ締付け後の参考寸法です。

めすストレート

●ATSM



(1袋10個入り)

チューブサイズ
4
6
8
10
12

注文記号

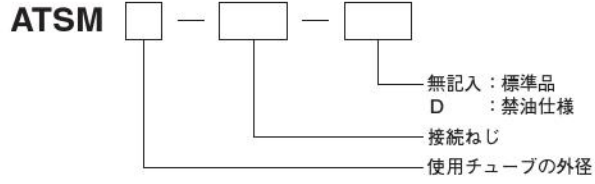

寸法図 (mm)

めすストレート
ATSM

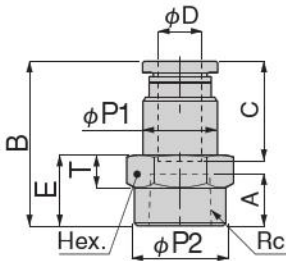

形式	チューブ外径 φD	Rc	A	B	E	φP1	φP2	C	対辺 Hex.	T	オリフィス径 (φmm)	質量 (g)
ATSM4-01-□	4	Rc1/8	7	23.9	10	9.7	13.8	14.9	14	5	3	13
ATSM4-02-□	4	Rc1/4	9.5	26.9	13	9.7	16.8	14.9	17	6	3	19
ATSM6-01-□	6	Rc1/8	7	26	10	11.8	13.8	17	14	5	5	15
ATSM6-02-□	6	Rc1/4	9.5	29	13	11.8	16.8	17	17	6	5	21
ATSM8-01-□	8	Rc1/8	7	27.2	10	13.7	13.8	18.2	14	5	7	16
ATSM8-02-□	8	Rc1/4	9.5	30.2	13	13.7	16.8	18.2	17	6	7	22
ATSM8-03-□	8	Rc3/8	10.5	31.2	14	13.7	20.8	18.2	21	6.5	7	30
ATSM10-02-□	10	Rc1/4	9.5	32.7	13	17.5	16.8	20.7	17	6	9	28
ATSM10-03-□	10	Rc3/8	10.5	33.7	14	17.5	20.8	20.7	21	6.5	9	37
ATSM12-02-□	12	Rc1/4	9.5	34.8	13.5	20.8	16.8	23.3	21	6.5	11	42
ATSM12-03-□	12	Rc3/8	10.5	36.3	14	20.8	20.8	23.3	21	6.5	11	44

*-□⇒無記入（標準品）とD（禁油仕様）の選択

●AUK



本体：アルミ（黒アルマイト）
ナット：軟鋼（亜鉛めっき）

（1袋10個入り）

チューブサイズ

4
6
8
10
12

注文記号

AUK



D：禁油仕様のみ
□：無記入（標準品）とD（禁油仕様）の選択

使用チューブの外径

寸法図 (mm)

隔壁ユニオン

AUK



形式	チューブ外径 φD	M	B	E	A	φP	C	対辺 Hex.	T	オリフィス径 (φmm)	質量 (g)
AUK4-D	4	M12×1	30.8	9.5	14.8	10.8	14.9	14	4	3	11
AUK6-D	6	M14×1	34.9	9.5	19	12.5	17	17	4	5	16
AUK8-□	8	M16×1	37.4	10.5	19.4	14.6	18.2	19	4	7	19
AUK10-□	10	M20×1	42.4	11.9	21.6	18.5	20.7	24	5	9	35
AUK12-□	12	M22×1	47.6	13.2	24.2	20.4	23.3	27	6	11	52

*-D ⇒ 禁油仕様のみ、-□ ⇒ 無記入（標準品）とD（禁油仕様）の選択

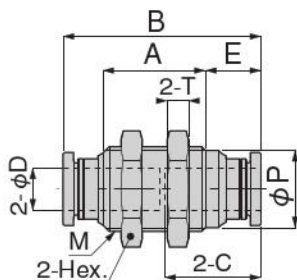

めす隔壁ユニオン

●AUKM



ナット：軟銅（亜鉛めっき）

（1袋10個入り）

チューブサイズ
4
6
8
10
12

注文記号

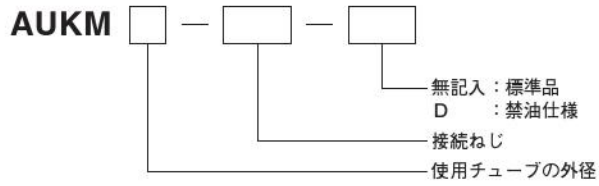

寸法図 (mm)

めす隔壁ユニオン
AUKM

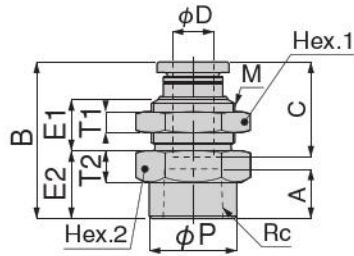

形式	チューブ外径 φD	Rc	M	B	E1	E2	A	C	φP	対辺 Hex.1	対辺 Hex.2	T1	T2	オリフィス径 (φmm)	質量 (g)
AUKM4-01-□	4	Rc1/8	M12×1	24.2	9	9	7	14.9	13.8	14	14	4	5	3	17
AUKM6-01-□	6	Rc1/8	M14×1	26.4	10.2	10	7	17	13.8	17	17	4	6	5	25
AUKM6-02-□	6	Rc1/4	M14×1	28.7	10.2	12.3	9.5	17	16.8	17	17	4	6	5	26
AUKM8-01-□	8	Rc1/8	M16×1	27	9.8	10	7	18.2	13.8	19	19	4	6	7	30
AUKM8-02-□	8	Rc1/4	M16×1	30	9.8	13	9.5	18.2	16.8	19	19	4	6	7	32
AUKM8-03-□	8	Rc3/8	M16×1	31	9.8	14	10.5	18.2	19.5	19	19	4	6	7	30
AUKM10-02-□	10	Rc1/4	M20×1	32.7	11.1	13	9.5	20.7	16.8	24	24	5	7	9	55
AUKM10-03-□	10	Rc3/8	M20×1	33.7	11.1	14	10.5	20.7	20.8	24	24	5	7	9	56
AUKM12-03-□	12	Rc3/8	M22×1	36.3	12.4	14	10.5	23.3	20.8	27	24	6	7	11	65
AUKM12-04-□	12	Rc1/2	M22×1	39.3	12.4	17	13	23.3	25	27	24	6	7	11	67

* □⇒無記入（標準品）とD（禁油仕様）の選択

エルボ

●ATL



チューブサイズ
4
6
8
10
12

(1袋10個入り)

注文記号

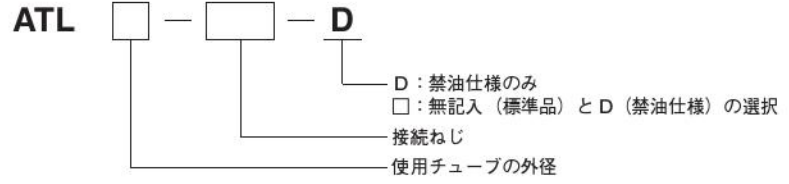

寸法図 (mm)

エルボ
ATL

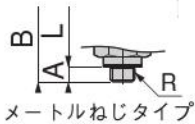
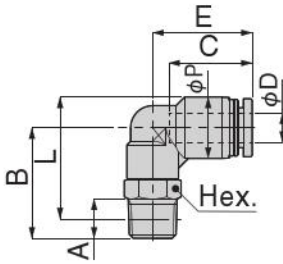

形式	チューブ外径 φD	R	A	B	L	φP	C	E	対辺 Hex.	オリフス径 (φmm)	質量 (g)
ATL4-M5-D	4	M5×0.8	2.8	16	18.2	10	14.9	17.7	8	2.4	5.7
ATL4-M6-D	4	M6×1	3.8	20	21.2	10	14.9	18.7	10	2.4	8.0
ATL4-01-D	4	R1/8	8	22	23	10	14.9	18.7	10	2.8	10
ATL4-02-□	4	R1/4	11	29	28	10	14.9	20.7	14	2.8	18
ATL6-M5-D	6	M5×0.8	2.8	19.5	23	12.5	17	20.3	10	2.4	8.9
ATL6-M6-D	6	M6×1	3.8	20.5	23	12.5	17	20.3	10	3	8.0
ATL6-01-D	6	R1/8	8	22.5	24.8	12.5	17	20.3	10	4.3	11
ATL6-02-□	6	R1/4	11	28	28.2	12.5	17	21.8	14	4.3	19
ATL6-03-□	6	R3/8	12	31.5	31.4	12.5	17	23.8	17	4.3	30
ATL8-01-□	8	R1/8	8	24	27.3	14.5	18.1	22.7	12	6	14
ATL8-02-□	8	R1/4	11	28	29.2	14.5	18.1	23.7	14	6.7	20
ATL8-03-□	8	R3/8	12	31	31.9	14.5	18.1	24.7	17	6.7	31
ATL10-01-□	10	R1/8	8	25	29.8	17.5	20.2	25.5	12	6	18
ATL10-02-□	10	R1/4	11	28.5	31.2	17.5	20.2	26	14	8	23
ATL10-03-□	10	R3/8	12	32	34.4	17.5	20.2	27	17	8.3	34
ATL10-04-□	10	R1/2	15	36	36.6	17.5	20.2	27.5	21	8.3	57
ATL12-02-□	12	R1/4	11	29.8	34.2	21	23.4	29	14	8	27
ATL12-03-□	12	R3/8	12	32.5	36.7	21	23.4	29.7	17	10	38
ATL12-04-□	12	R1/2	15	36.5	38.8	21	23.4	30.7	21	10.3	61

*D ⇒ 禁油仕様のみ、-□⇒ 無記入 (標準品) と D (禁油仕様) の選択

*テーパねじタイプのL寸法は、ねじ締付け後の参考寸法です。

●ATLL



(1袋10個入り)

チューブサイズ
4
6
8
10
12

注文記号

ATLL

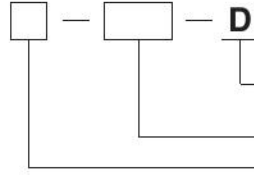

D : 禁油仕様のみ
 □ : 無記入 (標準品) と D (禁油仕様) の選択
 接続ねじ
 使用チューブの外径

寸法図 (mm)

ロングエルボ
ATLL

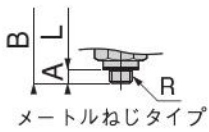
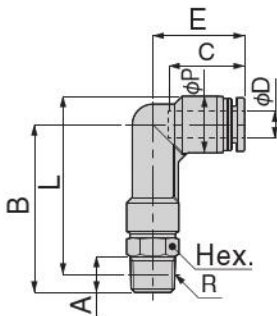

形式	チューブ外径 φD	R	A	B	L	φP	C	E	対辺 Hex.	オリフス径 (φmm)	質量 (g)
ATLL4-M5-D	4	M5×0.8	2.8	28	30.2	10	14.9	18.7	8	2.4	6.4
ATLL4-01-D	4	R1/8	8	34	35	10	14.9	18.7	10	2.8	11
ATLL6-01-D	6	R1/8	8	37	39.3	12.5	17	20.3	10	4.3	13
ATLL6-02-□	6	R1/4	11	42.5	42.7	12.5	17	21.8	14	4.3	20
ATLL6-03-□	6	R3/8	12	46	45.9	12.5	17	23.8	17	4.3	33
ATLL8-01-□	8	R1/8	8	40.5	43.8	14.5	18.1	22.7	12	6	16
ATLL8-02-□	8	R1/4	11	44.5	45.7	14.5	18.1	23.7	14	6.7	22
ATLL8-03-□	8	R3/8	12	47.5	48.4	14.5	18.1	24.7	17	6.7	35
ATLL10-02-□	10	R1/4	11	48	50.7	17.5	20.2	26	14	8	26
ATLL10-03-□	10	R3/8	12	51.5	53.9	17.5	20.2	27	17	8.3	38
ATLL10-04-□	10	R1/2	15	55.5	56.1	17.5	20.2	27	21	8.3	63
ATLL12-02-□	12	R1/4	11	52.8	57.2	21	23.4	29	14	8	30
ATLL12-03-□	12	R3/8	12	55.5	59.7	21	23.4	29.7	17	10	42
ATLL12-04-□	12	R1/2	15	59.5	61.8	21	23.4	29.7	21	10.3	68

*-D ⇒ 禁油仕様のみ、-□ ⇒ 無記入 (標準品) と D (禁油仕様) の選択
 *テーパねじタイプのL寸法は、ねじ締付け後の参考寸法です。

テ
イ
ー

●ATT



チューブサイズ

4
6
8
10
12

(1袋10個入り)

注文記号

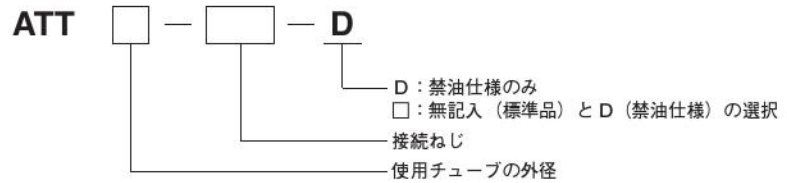

寸法図 (mm)

テ
イ
ー
ATT

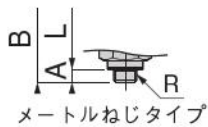
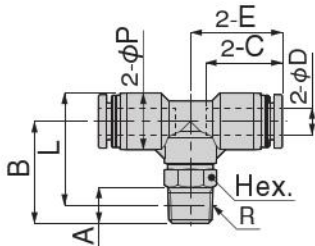

形 式	チューブ外径 φD	R	A	B	L	φP	C	E	対辺 Hex.	オリフス径 (φmm)	質量 (g)
ATT4-M5-D	4	M5×0.8	2.8	16	18.2	10	14.9	17.7	8	2.4	8
ATT4-M6-D	4	M6×1	3.8	20	21.2	10	14.9	18.7	10	2.4	11
ATT4-01-D	4	R1/8	8	22	23	10	14.9	18.7	10	2.8	13
ATT4-02-□	4	R1/4	11	29	28	10	14.9	20.7	14	2.8	20
ATT6-M5-D	6	M5×0.8	2.8	19.5	23	12.5	17	20.25	10	2.4	12
ATT6-M6-D	6	M6×1	3.8	20.5	23	12.5	17	20.25	10	3	13
ATT6-01-D	6	R1/8	8	22.5	24.8	12.5	17	20.25	10	4.3	14
ATT6-02-□	6	R1/4	11	28	28.2	12.5	17	21.75	14	4.3	22
ATT6-03-□	6	R3/8	12	31.5	31.4	12.5	17	23.75	17	4.3	33
ATT8-01-□	8	R1/8	8	24	27.3	14.5	18.1	22.7	12	6	19
ATT8-02-□	8	R1/4	11	28	29.2	14.5	18.1	23.7	14	6.7	25
ATT8-03-□	8	R3/8	12	31	31.9	14.5	18.1	24.7	17	6.7	35
ATT10-02-□	10	R1/4	11	28.5	31.2	17.5	20.2	26	14	8	31
ATT10-03-□	10	R3/8	12	32	34.4	17.5	20.2	27	17	8.3	42
ATT10-04-□	10	R1/2	15	36	36.6	17.5	20.2	27.5	21	8.3	65
ATT12-02-□	12	R1/4	11	29.8	34.2	21	23.4	28.95	14	8	38
ATT12-03-□	12	R3/8	12	32.5	36.7	21	23.4	29.7	17	10	48
ATT12-04-□	12	R1/2	15	36.5	38.8	21	23.4	30.7	21	10.3	72

*D ⇒ 禁油仕様のみ、-□ ⇒ 無記入 (標準品) と D (禁油仕様) の選択

*テーパねじタイプのL寸法は、ねじ締付け後の参考寸法です。

ブランチティー

●ATB



(1袋10個入り)

チューブサイズ

4
6
8
10
12

注文記号

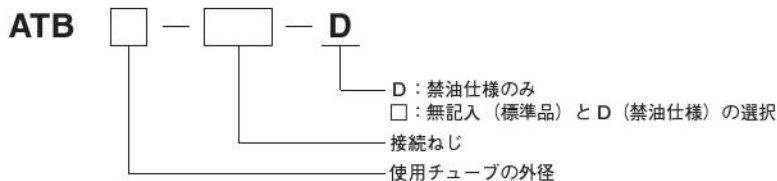

寸法図 (mm)

ブランチティー
ATB

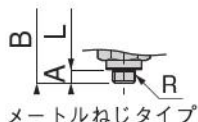
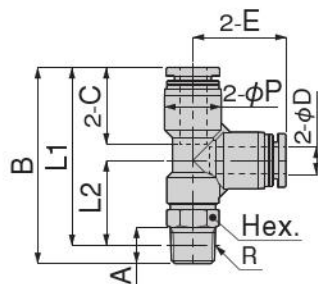

形式	チューブ外径 φD	R	A	B	L1	L2	φP	C	E	対辺 Hex.	オアリス径 (φmm)	質量 (g)
ATB4-M5-D	4	M5×0.8	2.8	33.7	30.9	13.7	10	14.9	17.2	8	2.4	7.8
ATB4-M6-D	4	M6×1	3.8	38.2	34.4	17.2	10	14.9	17.2	10	2.4	11
ATB4-01-D	4	R1/8	8	40.2	36.2	19	10	14.9	17.2	10	2.8	13
ATB4-02-□	4	R1/4	11	46.2	40.2	23	10	14.9	19.2	14	2.8	20
ATB6-M5-D	6	M5×0.8	2.8	40.3	37.5	17	12.5	17	20.5	10	2.4	12
ATB6-M6-D	6	M6×1	3.8	41.3	37.5	17	12.5	17	20.5	10	3	12
ATB6-01-D	6	R1/8	8	43.3	39.3	18.8	12.5	17	20.5	10	4.3	14
ATB6-02-□	6	R1/4	11	48.8	42.7	22.2	12.5	17	20.5	14	4.3	22
ATB6-03-□	6	R3/8	12	52	45.7	25.2	12.5	17	21.5	17	4.3	32
ATB8-01-□	8	R1/8	8	46.9	42.9	20	14.5	18.1	22.9	12	6	19
ATB8-02-□	8	R1/4	11	51.7	45.7	22.8	14.5	18.1	22.9	14	6.7	25
ATB8-03-□	8	R3/8	12	55.4	49.1	26.2	14.5	18.1	22.9	17	6.7	35
ATB10-02-□	10	R1/4	11	54.7	48.7	22.5	17.5	20.2	26.2	14	8	31
ATB10-03-□	10	R3/8	12	58.2	51.9	25.7	17.5	20.2	26.2	17	8.3	42
ATB10-04-□	10	R1/2	15	62.2	54	27.8	17.5	20.2	27.3	21	8.3	65
ATB12-02-□	12	R1/4	11	60.3	54.2	23.7	21	23.4	30	14	8	38
ATB12-03-□	12	R3/8	12	63.5	57.2	26.7	21	23.4	30.5	17	10	48
ATB12-04-□	12	R1/2	15	67.5	59.3	28.8	21	23.4	30.7	21	10.3	72

*D ⇒ 禁油仕様のみ、□ ⇒ 無記入 (標準品) と D (禁油仕様) の選択

*テーパねじタイプのL寸法は、ねじ締付け後の参考寸法です。

ブランチワイ

●ATBY



(1袋10個入り)

チューブサイズ
4
6
8
10
12

注文記号

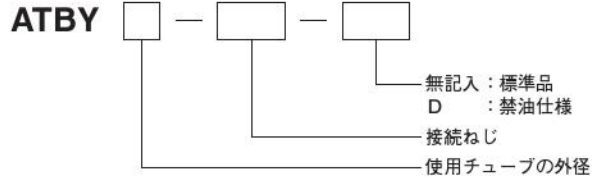

寸法図 (mm)

ブランチワイ
ATBY

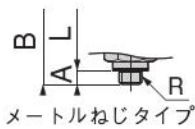
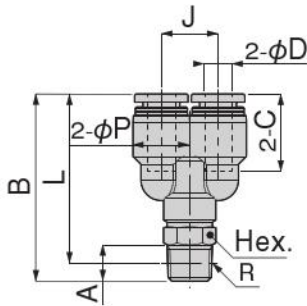

形式	チューブ外径 φD	R	A	B	L	φP	C	J	φd	F	T	対辺 Hex.	オフセット (φmm)	質量 (g)
ATBY4-M5-□	4	M5×0.8	2.8	32.9	30.1	10	14.9	10.3	—	—	—	8	2.4	8
ATBY4-01-□	4	R1/8	8	38.4	34.4	10	14.9	10.3	—	—	—	10	2.8	13
ATBY4-02-□	4	R1/4	11	43.4	37.4	10	14.9	10.3	—	—	—	14	2.8	20
ATBY6-M5-□	6	M5×0.8	2.8	38.3	35.5	12.5	17	12.5	—	—	—	10	2.4	13
ATBY6-M6-□	6	M6×1	3.8	39.3	35.5	12.5	17	12.5	—	—	—	10	3	13
ATBY6-01-□	6	R1/8	8	41.3	37.3	12.5	17	12.5	—	—	—	10	4.3	15
ATBY6-02-□	6	R1/4	11	48.3	42.2	12.5	17	12.5	—	—	—	14	4.3	22
ATBY6-03-□	6	R3/8	12	51.3	44.9	12.5	17	12.5	—	—	—	17	4.3	33
ATBY8-01-□	8	R1/8	8	46.1	42.1	14.5	18.1	14.5	—	—	—	12	6	20
ATBY8-02-□	8	R1/4	11	49.3	43.3	14.5	18.1	14.5	—	—	—	14	6.7	25
ATBY8-03-□	8	R3/8	12	52.5	46.2	14.5	18.1	14.5	—	—	—	17	6.7	36
ATBY10-02-□	10	R1/4	11	53.6	47.6	17.5	20.2	17.5	—	—	—	14	8	32
ATBY10-03-□	10	R3/8	12	56.7	50.4	17.5	20.2	17.5	—	—	—	17	8.3	43
ATBY10-04-□	10	R1/2	15	60.2	52	17.5	20.2	17.5	—	—	—	21	8.3	66
ATBY12-02-□	12	R1/4	11	58.6	52.6	21	23.4	21	—	—	—	14	8	40
ATBY12-03-□	12	R3/8	12	60.6	54.3	21	23.4	21	—	—	—	17	10	51
ATBY12-04-□	12	R1/2	15	64.7	56.5	21	23.4	21	—	—	—	21	10.3	74

*-□⇒無記入（標準品）とD（禁油仕様）の選択
 *テーパねじタイプのL寸法は、ねじ締付け後の参考寸法です。

●ATBLY



(1袋10個入り)

チューブサイズ
4
6
8
10
12

注文記号

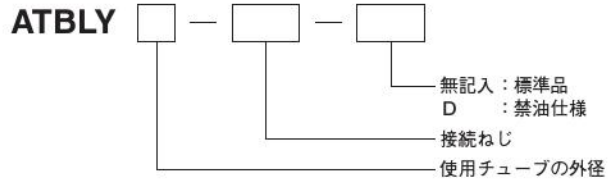

寸法図 (mm)

ブランチエルボワイ
ATBLY

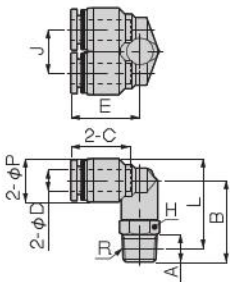

メートルねじタイプ

形式	チューブ外径 φD	R	A	B	L [※]	φP	C	J	E	対辺 H	材質径 (φmm)	質量 (g)
ATBLY4-M5-□	4	M5×0.8	2.8	20	22.2	10	14.9	10.3	18.2	10	2.4	11
ATBLY4-M6-□		M6×1	3.8	21							3	
ATBLY4-01-□		R1/8	8	23	24				3.9	20		
ATBLY4-02-□		R1/4	11	27	26							
ATBLY6-M5-□	6	M5×0.8	2.8	20.5	24	12.5	17	12.5	19.8	10	2.4	12
ATBLY6-M6-□		M6×1	3.8	21.5							3	
ATBLY6-01-□		R1/8	8	23.5	25.8				4.2	15		
ATBLY6-02-□		R1/4	11	29	29.2						21.8	14
ATBLY6-03-□	R3/8	12	31.5	31.4	23.8	17	34					
ATBLY8-01-□	8	R1/8	8	25	28.3	14.5	18.1	14.5	22.7	12	5.7	20
ATBLY8-02-□		R1/4	11	29	30.2				23.7	14	7.3	25
ATBLY8-03-□		R3/8	12	32	32.9				24.7	17		
ATBLY10-02-□	10	R1/4	11	29.5	32.2	17.5	20.2	17.5	26	14	8	32
ATBLY10-03-□		R3/8	12	32.5	34.9				27	17	9.2	43
ATBLY10-04-□		R1/2	15	37	37.6				28	21		
ATBLY12-02-□	12	R1/4	11	29.5	34	21	23.4	21	28.2	14	8	39
ATBLY12-03-□		R3/8	12	33.5	37.7				29.2	17	9.7	51
ATBLY12-04-□		R1/2	15	38	40.3				30.2	21	10.6	74

* □⇒無記入（標準品）とD（禁油仕様）の選択

* テーパーねじタイプのL寸法は、ねじ締付け後の参考寸法です。

ブランチ2重ワイ

●ATBW



(1袋10個入り)

チューブサイズ

4

6

注文記号

ATBW

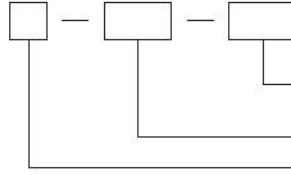

無記入：標準品
D：禁油仕様
接続ねじ
使用チューブの外径

寸法図 (mm)

ブランチ2重ワイ
ATBW



形 式	チューブ外径 φD	R	A	B	L ^注	φP	C	J	対辺 H	オアサイズ (φmm)	質量 (g)
ATBW4-01-□	4	R1/8	8	38.9	34.9	10.5	14.9	10.3	12	2.6	16
ATBW4-02-□		R1/4	11	42.4	36.4				14		
ATBW6-01-□	6	R1/8	8	47.2	43.2	13	17	12.5	12	5.2	25

*-□⇒無記入（標準品）とD（禁油仕様）の選択

*テーパねじタイプのL寸法は、ねじ締付け後の参考寸法です。

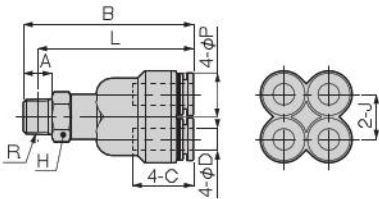

ブランチトリプル

●ATBE



(1袋10個入り)

チューブサイズ

6-4
8-4
8-6
10-8

注文記号

ATBE

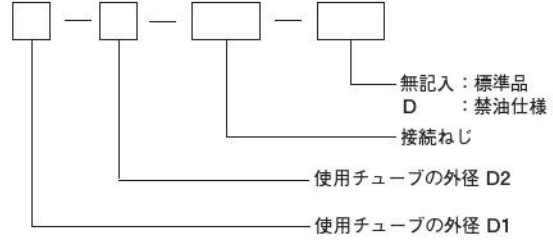

寸法図 (mm)

ブランチトリプル
ATBE

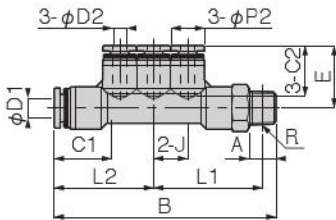
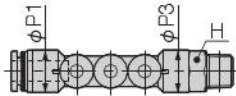

形式	チューブ外径 φD1	チューブ外径 φD2	R	A	B	E	L1 ^注	L2	J	φP1	φP2	φP3
ATBE6-4-01-□	6	4	R1/8	8	65.4	18.4	32.1	29.3	10	12.5	10	12.5
ATBE8-4-02-□	8	4	R1/4	11	69.2	19.2	32	31.2	10	14.5		12.5
ATBE8-6-02-□		6		11	76.9	21.3	36.5	34.4	12.5			
ATBE10-8-03-□	10	8	R3/8	12	87.8	23.7	41.5	40	14.5	17.5	14.5	18

形式	C1	C2	対辺 H	初アス径 (φmm)	質量 (g)
ATBE6-4-01-□	17	14.9	12	3	21
ATBE8-4-02-□	18.1	14.9	14	3	28
ATBE8-6-02-□	18.1	17		4.6	35
ATBE10-8-03-□	20.2	18.1	17	6.7	50

*-□⇒無記入（標準品）とD（禁油仕様）の選択

*テーパねじタイプのL寸法は、ねじ締付け後の参考寸法です。

ブランチトリプルダブル

●ATBEW



(1袋10個入り)

チューブサイズ
8-4
8-6
10-6
10-8

注文記号

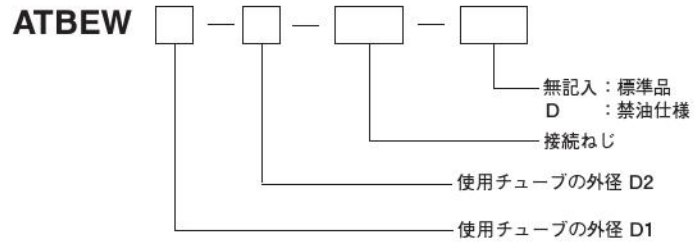

寸法図 (mm)

ブランチトリプルダブル
ATBEW

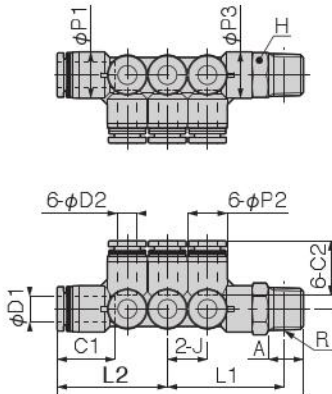

形式	チューブ外径 $\phi D1$	チューブ外径 $\phi D2$	R	A	B	E	L1 ^注	L2	J	$\phi P1$	$\phi P2$	$\phi P3$
ATBEW8-4-02-□	8	4	R1/4	11	69.2	19.2	32	31.2	10	14.5	10	14.5
ATBEW8-4-03-□			R3/8	12	72.2		37.7					18
ATBEW8-6-02-□		6	R1/4	11	76.9	21.3	36.5					34.4
ATBEW8-6-03-□	R3/8		12	80.7	39.9		18					
ATBEW10-6-03-□	10	6	R3/8	12	81.5	22.3	38.2	37	17.5	17.5	14.5	20
ATBEW10-6-04-□			R1/2	15	85.5		40.3					20
ATBEW10-8-03-□		8	R3/8	12	87.8	23.7	41.5	40	14.5	14.5	18	20
ATBEW10-8-04-□	R1/2		15	91.8	43.6		20					

形式	C1	C2	対辺 H	ボア径 (ϕ mm)	質量 (g)
ATBEW8-4-02-□	18.1	14.9	14	3	32
ATBEW8-4-03-□			17		46
ATBEW8-6-02-□		14	41		
ATBEW8-6-03-□	17	17	4.6	52	
ATBEW10-6-03-□				56	
ATBEW10-6-04-□	20.2	21	6.7	78	
ATBEW10-8-03-□				17	65
ATBEW10-8-04-□		18.1	21	87	

*-□⇒無記入（標準品）とD（禁油仕様）の選択
*テーパねじタイプのL寸法は、ねじ締付け後の参考寸法です。

●ATBZ



(1袋10個入り)

チューブサイズ
4
6
8
10
12

注文記号

ATBZ

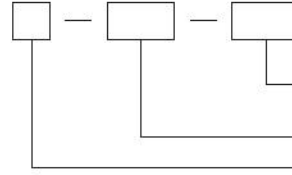

無記入：標準品
D：禁油仕様
接続ねじ
使用チューブの外径

寸法図 (mm)

ブランチテトラ
ATBZ

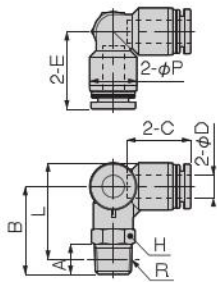

メートルねじタイプ

形式	チューブ外径 φD	R	A	B	L ^注	φP	C	E	対辺 H	オフ径 (φmm)	質量 (g)
ATBZ4-M5-□	4	M5×0.8	2.8	20.3	22.5	10	14.9	18.2	10	2.4	10
ATBZ4-M6-□		M6×1	3.8	21.3							
ATBZ4-01-□		R1/8	8	23.3	24.3			20.7	14	3	13
ATBZ4-02-□		R1/4	11	29							
ATBZ6-M5-□	6	M5×0.8	2.8	20.3	23.7	12.5	17	20.5	10	2.4	12
ATBZ6-M6-□		M6×1	3.8	21.3							
ATBZ6-01-□		R1/8	8	23.3	25.5			21.8	14	4.6	15
ATBZ6-02-□		R1/4	11	28							
ATBZ6-03-□	R3/8	12	31.5	31.4	23.8	17	33				
ATBZ8-01-□	8	R1/8	8	25	28.3	14.5	18.1	22.7	12	6	20
ATBZ8-02-□		R1/4	11	29	30.2			23.7	14	6.7	25
ATBZ8-03-□		R3/8	12	32	32.9			24.7	17	36	
ATBZ10-02-□	10	R1/4	11	29.4	32.1	17.5	20.2	26	14	8	31
ATBZ10-03-□		R3/8	12	33	35.4			27	17	8.3	42
ATBZ10-04-□		R1/2	15	37	37.6			27.5	21	66	
ATBZ12-02-□	12	R1/4	11	30.8	35.2	21	23.4	30.2	14	8	37
ATBZ12-03-□		R3/8	12	33.5	37.7			17	10	49	
ATBZ12-04-□		R1/2	15	38	40.3			31.2	21	10.3	74

* □⇒無記入 (標準品) と D (禁油仕様) の選択

* テーパねじタイプのL寸法は、ねじ締付け後の参考寸法です。

●ASKR



メイン側ねじサイズ	サブメイン側チューブサイズ				
	4	6	8	10	12
M8×1 (8)	8-4	8-6	—	—	—
M12×1 (12)	—	12-6	12-8	12-10	—
M14×1 (14)	—	—	14-8	14-10	14-12
M18×1 (18)	—	—	—	—	18-12

注文記号

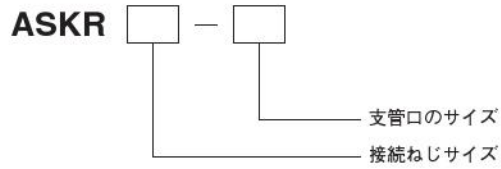

寸法図 (mm)

隔壁レデューサ
ASKR

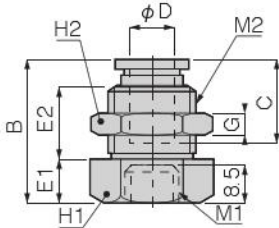

形 式	チューブ外径 φD	M1	M2	B	E1	E2	C	G	対辺 H1	対辺 H2	有効断面積 (mm ²)	質量 (g)
ASKR8-4	4	M8×1	M12×1	26	8	11.8	14.9	4	14	14	5.6	18
ASKR8-6	6		M14×1	28.1		13.9	17		17	17	11.5	29
ASKR12-6	6	M12×1	M14×1	28.1	12	9.9	17	4	17	17	13.2	28
ASKR12-8	8		M16×1	28.9	10	11.7	18.2		19	19	27.4	33
ASKR12-10	10		M20×1	32.3		13.7	20.7		5	22	24	34.8
ASKR14-8	8	M14×1	M16×1	28.9	12	9.7	18.2	4	19	19	27.7	32
ASKR14-10	10		M20×1	32.3	10	13.7	20.7	5	24	24	41.7	60
ASKR14-12	12		M22×1	34.9	12	13	23.3	6		27	54.7	74
ASKR18-12	12	M18×1	M22×1	34.9	12	13	23.3	6	27	27	66.7	79

TS/ATS ストレート

●現行品 TS

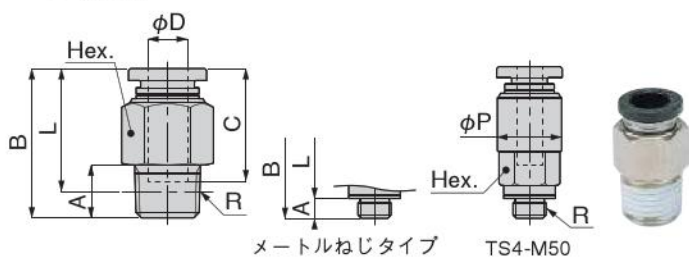

●新形状 ATS

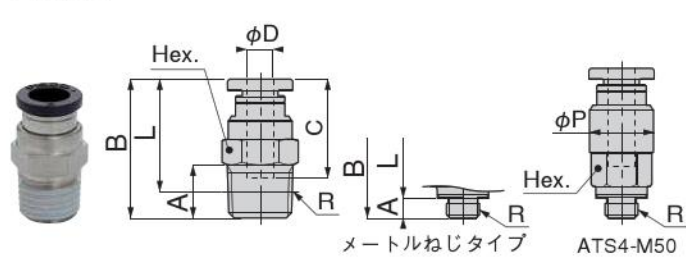

■は、新形式（新形状）で寸法が変更された部分です。

単位：mm

形式	チューブ外径 φD	R	A	B	L	C	対辺 Hex.	φP	オリフィス径 (φmm)	質量 (g)
TS4-M5-D	4	M5×0.8	3	20	17	14.9	10	-	1.8	6.3
ATS4-M5-D			2.8	19.8					2.4	5.6
TS4-M50-□	4	M5×0.8	3	22.9	19.9	14.9	8	9.7	1.8	6.6
ATS4-M50-□			2.8	22.7					2.4	6.1
TS4-M6-D	4	M6×1	4	21	17	14.9	10	-	3	6.4
ATS4-M6-D			3.8	20.8					3	6.0
TS4-01-D	4	R1/8	8	21	17	14.9	10	-	3	8.3
ATS4-01-D									3	7.4
TS4-02-□	4	R1/4	11	21	15	14.9	14	-	3	16
ATS4-02-□				22.5					16.5	
TS6-M5-D	6	M5×0.8	3	22.1	19.1	17	12	-	1.8	9.2
ATS6-M5-D			2.8	21.9					2.4	8.1
TS6-M6-D	6	M6×1	4	23.1	19.1	17	12	-	3	9.4
ATS6-M6-D			3.8	22.9					3	8.5
TS6-01-D	6	R1/8	8	22.6	18.6	17	12	-	4.6	9.3
ATS6-01-D				22.3	18.3				5	8.2
TS6-02-□	6	R1/4	11	24.6	18.5	17	14	-	4.6	18
ATS6-02-□				23.7	17.6				5	15
TS6-03-□	6	R3/8	12	23.6	17.2	17	17	-	4.6	28
ATS6-03-□				24.5	18.1				5	
TS8-01-□	8	R1/8	8	27.9	23.9	18.2	14	-	6	16
ATS8-01-□									6	14
TS8-02-□	8	R1/4	11	26.6	20.6	18.2	14	-	7	16
ATS8-02-□									7	14
TS8-03-□	8	R3/8	12	23.9	17.6	18.2	17	-	7	24
ATS8-03-□				25.5	19.2				7	25
TS10-01-□	10	R1/8	8	30.3	26.3	20.7	17	-	6	24
ATS10-01-□									6	21
TS10-02-□	10	R1/4	11	29.8	23.8	20.7	17	-	8.5	21
ATS10-02-□									8.5	19
TS10-03-□	10	R3/8	12	29.3	23	20.7	17	-	8.5	27
ATS10-03-□									9	24
TS10-04-□	10	R1/2	15	30.3	22.1	20.7	21	-	8.5	50
ATS10-04-□				30.4	22.2				9	46
TS12-02-□	12	R1/4	11	35.9	29.9	23.3	21	-	8.5	44
ATS12-02-□									8.5	37
TS12-03-□	12	R3/8	12	31.9	25.6	23.3	21	-	11	36
ATS12-03-□									11	30
TS12-04-□	12	R1/2	15	33.9	25.7	23.3	21	-	11	50
ATS12-04-□									11	44
TS16-03-□	16	R3/8	12	39.3	33	24.8	24	-	11	58
ATS16-03-□									11	54
TS16-04-□	16	R1/2	15	41.3	33.1	24.8	24	-	13	66
ATS16-04-□									13	63

*D⇒禁油仕様のみ、-□⇒無記入（標準品）とD（禁油仕様）の選択

*テーパねじタイプのL寸法は、ねじ締付け後の参考寸法です。

*価格に変更はありません。

TSH/ATSH 六角穴付ストレート

●現行品 TSH

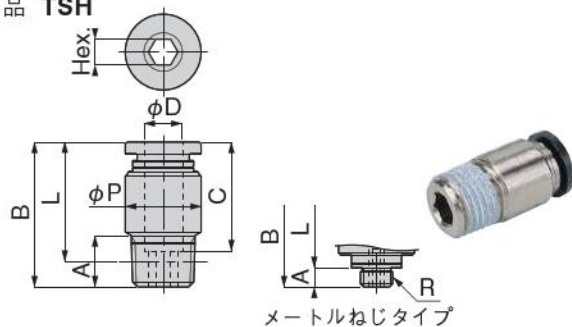

●新形状 ATSH

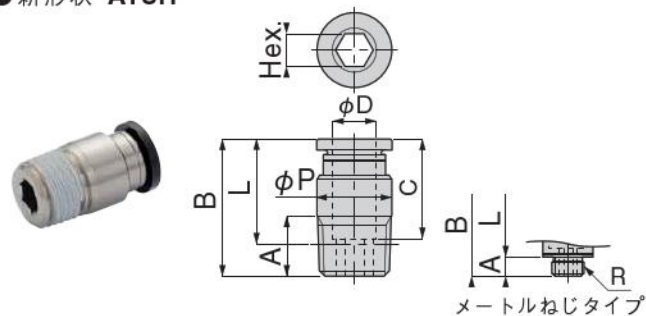

単位：mm

形式	チューブ外径 φD	R	A	B	L	C	対辺 Hex.	φP	オリフィス径 (φmm)	質量 (g)
TSH4-M5-D	4	M5×0.8	3	19.9	16.9	14.9	2	9.7	2	5.6
ATSH4-M5-D			2.8	19.7			2.5			
TSH4-M6-D	4	M6×1	4	20.9	16.9	14.9	3	9.7	3.1	5.9
ATSH4-M6-D			3.8	20.7			2.5*			
TSH4-01-D	4	R1/8	8	21	17	14.9	2.5	9.7	2.6	7.6
ATSH4-01-D				20	16					6.6
TSH6-M5-D	6	M5×0.8	3	23	20	17	2	11.8	2	8.5
ATSH6-M5-D				2.8	21.3					
TSH6-M6-D	6	M6×1	4	22.5	18.5	17	3	11.8	3.2	6.9
ATSH6-M6-D				3.8						
TSH6-01-D	6	R1/8	8	22.6	18.6	17	4	11.8	4.2	8.1
ATSH6-01-D				22.1	18.1					7.6
TSH6-02-□	6	R1/4	11	22.6	16.5	17	4	14	4.2	15
ATSH6-02-□				21.3	15.2			13.7		13
TSH8-01-□	8	R1/8	8	27.9	23.9	18.2	5	13.7	5.3	14
ATSH8-01-□				25.9	21.9					8.8
TSH8-02-□	8	R1/4	11	26.6	20.6	18.2	6	13.7	6.3	15
ATSH8-02-□				25.1	19.1					13
TSH8-03-□	8	R3/8	12	23.9	17.6	18.2	6	16.8	6.3	23
ATSH8-03-□				22.2	15.9					19
TSH10-02-□	10	R1/4	11	29.8	23.8	20.7	6	17.7	6.3	23
ATSH10-02-□								17.5		20
TSH10-03-□	10	R3/8	12	29.3	23	20.7	6	17.7	6.3	28
ATSH10-03-□								17.5		26
TSH10-04-□	10	R1/2	15	30.3	22.1	20.7	6	20.8	6.3	49
ATSH10-04-□										45
TSH12-03-□	12	R3/8	12	31.9	25.6	23.3	8	20.8	8.4	34
ATSH12-03-□										31
TSH12-04-□	12	R1/2	15	33.9	25.7	23.3	8	20.8	8.4	49
ATSH12-04-□										45

※六角レンチ干渉によるロック爪不具合を改善するため、内径六角対辺を見直し、オリフィス径が変更になりました。

*D⇒禁油仕様のみ、-□⇒無記入(標準品)とD(禁油仕様)の選択

*テーパねじタイプのL寸法は、ねじ締付け後の参考寸法です。

*価格に変更はありません。

TSM/ATSM めすストレート

● 現行品 TSM

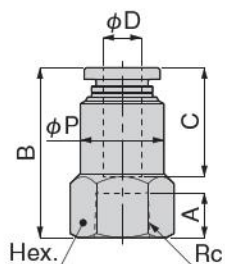

● 新形状 ATSM

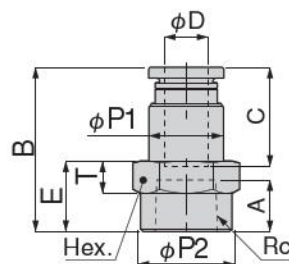

単位：mm

形式	チューブ外径 φD	Rc	A	B	E	φP1	φP2	C	対辺 Hex.	T	オリフィス径 (φ mm)	質量 (g)
TSM4-01-□	4	Rc1/8	7	24.4	-	11	-	14.9	14	-	3	16
ATSM4-01-□				23.9	10	9.7	13.8					13
TSM4-02-□	4	Rc1/4	9.5	27.4	-	12	-	14.9	17	-	3	24
ATSM4-02-□				26.9	13	9.7	16.8					19
TSM6-01-□	6	Rc1/8	7	26.5	-	13	-	17	14	-	4.6	18
ATSM6-01-□				26	10	11.8	13.8					15
TSM6-02-□	6	Rc1/4	9.5	29.5	-	13	-	17	17	-	4.6	25
ATSM6-02-□				29	13	11.8	16.8					21
TSM8-01-□	8	Rc1/8	7	28	-	14.5	-	18.2	14	-	6	20
ATSM8-01-□				27.2	10	13.7	13.8					16
TSM8-02-□	8	Rc1/4	9.5	31	-	15	-	18.2	17	-	6	27
ATSM8-02-□				30.2	13	13.7	16.8					22
TSM8-03-□	8	Rc3/8	10.5	32	-	15.5	-	18.2	21	-	6	37
ATSM8-03-□				31.2	14	13.7	20.8					30
TSM10-02-□	10	Rc1/4	9.5	33.7	-	17.5	-	20.7	17	-	8.5	33
ATSM10-02-□				32.7	13	17.5	16.8					28
TSM10-03-□	10	Rc3/8	10.5	34.7	-	17.5	-	20.7	21	-	8.5	42
ATSM10-03-□				33.7	14	17.5	20.8					37
TSM12-02-□	12	Rc1/4	9.5	35.8	-	20.8	-	23.3	21	-	11	57
ATSM12-02-□				34.8	13.5	20.8	16.8					42
TSM12-03-□	12	Rc3/8	10.5	36.8	-	20.8	-	23.3	21	-	11	51
ATSM12-03-□				36.3	14	20.8	20.8					44

* - □ ⇒ 無記入 (標準品) と D (禁油仕様) の選択

* 価格に変更はありません。

UK/AUK 隔壁ユニオン

●現行品 UK

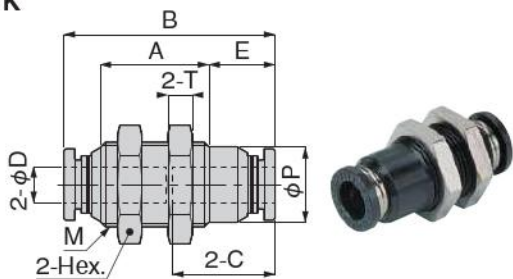

●新形状 AUK

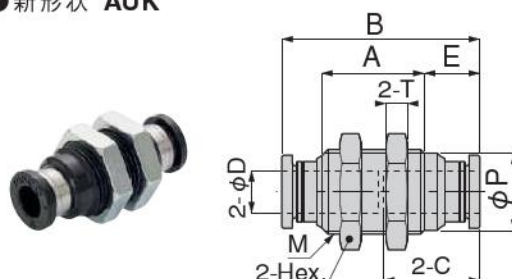

単位：mm

形式	チューブ外径 φD	M	B	E	A	φP	C	対辺 Hex.	T	オリフィス径 (φmm)	質量 (g)
UK4-D	4	M12×1	30.8	10.4	15	10.8	14.9	14	4	3	11
AUK4-D				9.5	14.8						
UK6-D	6	M14×1	34.9	11	18	12.5	17	17	4	4.6	16
AUK6-D				9.5	19					5	
UK8-□	8	M16×1	37.4	14.3	16.8	14.6	18.2	19	4	6	20
AUK8-□				10.5	19.4					7	
UK10-□	10	M20×1	42.4	12.7	23	18.5	20.7	24	5	8	39
AUK10-□				11.9	21.6					9	
UK12-□	12	M22×1	47.6	12.3	29	20.4	23.3	27	6	11	57
AUK12-□				13.2	24.2					11	

*-D ⇒ 禁油仕様のみ、-□ ⇒ 無記入 (標準品) と D (禁油仕様) の選択

* 価格に変更はありません。

UKM/AUKM めす隔壁ユニオン

● 現行品 UKM

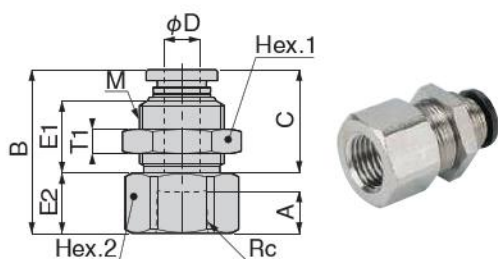

● 新形状 AUKM

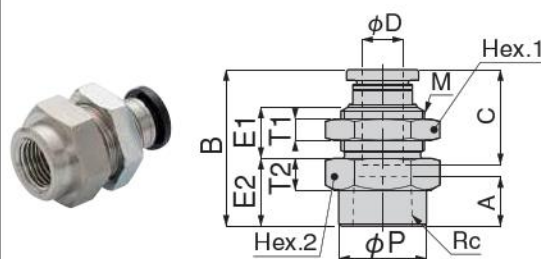

単位：mm

形式	チューブ外径 φD	Rc	M	B	E1	E2	A	C	φP	対辺 Hex.1	対辺 Hex.2	T1	T2	オフィス径 (φmm)	質量 (g)
UKM4-01-□	4	Rc1/8	M12×1	24.5	9.9	10	7	14.9	-	14	14	4	-	3	19
AUKM4-01-□				24.2	9	9			13.8				5		
UKM6-01-□	6	Rc1/8	M14×1	27.1	11.9	10	7	17	-	17	17	4	-	4.6	29
AUKM6-01-□				26.4	10.2	10			13.8				6		
UKM6-02-□	6	Rc1/4	M14×1	30.1	11.9	13	9.5	17	-	17	17	4	-	4.6	29
AUKM6-02-□				28.7	10.2	12.3			16.8				6		
UKM8-01-□	8	Rc1/8	M16×1	29	13.5	10	7	18.2	-	19	19	4	-	6	39
AUKM8-01-□				27	9.8	10			13.8				6		
UKM8-02-□	8	Rc1/4	M16×1	32	13.5	13	9.5	18.2	-	19	19	4	-	6	41
AUKM8-02-□				30	9.8	13			16.8				6		
UKM8-03-□	8	Rc3/8	M16×1	33	13.5	14	10.5	18.2	-	19	19	4	-	6	35
AUKM8-03-□				31	9.8	14			19.5				6		
UKM10-02-□	10	Rc1/4	M20×1	34.8	14.9	14	9.5	20.7	-	24	24	5	-	8.5	78
AUKM10-02-□				32.7	11.1	13			16.8				7		
UKM10-03-□	10	Rc3/8	M20×1	35.8	14.9	15	10.5	20.7	-	24	24	5	-	8.5	73
AUKM10-03-□				33.7	11.1	14			20.8				7		
UKM12-03-□	12	Rc3/8	M22×1	38.9	18.4	15	10.5	23.3	-	27	24	6	-	11	86
AUKM12-03-□				36.3	12.4	14			20.8				7		
UKM12-04-□	12	Rc1/2	M22×1	41.9	18.4	18	13	23.3	-	27	24	6	-	11	80
AUKM12-04-□				39.3	12.4	17			25				7		

* □⇒無記入（標準品）とD（禁油仕様）の選択

* 価格に変更はありません。

TL/ATL エルボ

● 現行品 TL

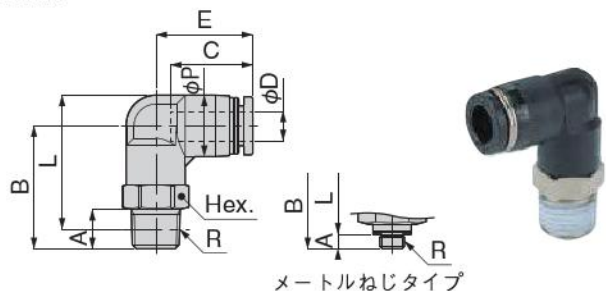

● 新形状 ATL

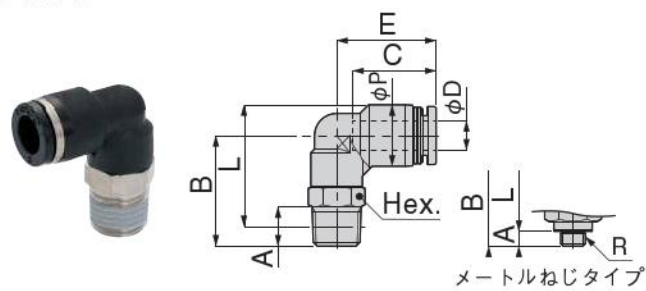

単位：mm

形式	チューブ外径 φD	R	A	B	L	φP	C	E	対辺 Hex.	オリフス径 (φmm)	質量 (g)
TL4-M5-D	4	M5×0.8	3	20.3	22.3	10	14.9	18	10	1.8	8
ATL4-M5-D			2.8	16	18.2			17.7			
TL4-M6-D	4	M6×1	4	21.3	22.3	10	14.9	18	10	2.4	8.3
ATL4-M6-D			3.8	20	21.2			18.7			
TL4-01-D	4	R1/8	8	23.3	24.3	10	14.9	18	10	2.8	11
ATL4-01-D				22	23			18.7			
TL4-02-□	4	R1/4	11	26.3	25.3	10	14.9	18	14	2.8	21
ATL4-02-□				29	28			20.7			
TL6-M5-D	6	M5×0.8	3	22	25.3	12.5	16.8	19.8	12	1.8	13
ATL6-M5-D			2.8	19.5	23			17			
TL6-M6-D	6	M6×1	4	23	25.3	12.5	16.8	19.8	12	3	13
ATL6-M6-D			3.8	20.5	23			17			
TL6-01-D	6	R1/8	8	25	27.3	12.5	16.8	19.8	12	4.3	14
ATL6-01-D				22.5	24.8			17			
TL6-02-□	6	R1/4	11	28	28.2	12.5	16.8	19.8	14	4.3	22
ATL6-02-□								17			
TL6-03-□	6	R3/8	12	29.8	29.7	12.5	16.8	19.8	17	4.3	35
ATL6-03-□				31.5	31.4			17			
TL8-01-□	8	R1/8	8	28	31.3	14.5	18.1	22.7	14	6	19
ATL8-01-□				24	27.3			14.5			
TL8-02-□	8	R1/4	11	31	32.2	14.5	18.1	22.7	14	6	24
ATL8-02-□				28	29.2			14.5			
TL8-03-□	8	R3/8	12	32.8	33.7	14.5	18.1	22.7	17	6	37
ATL8-03-□				31	31.9			14.5			
TL10-01-□	10	R1/8	8	33	37.8	17.5	20.2	26.2	17	6	31
ATL10-01-□				25	29.8			17.5			
TL10-02-□	10	R1/4	11	36	38.7	17.5	20.2	26.2	17	8	34
ATL10-02-□				28.5	31.2			17.5			
TL10-03-□	10	R3/8	12	37	39.4	17.5	20.2	26.2	17	8	43
ATL10-03-□				32	34.4			17.5			
TL10-04-□	10	R1/2	15	40	40.6	17.5	20.2	26.2	21	8	65
ATL10-04-□				36	36.6			17.5			
TL12-02-□	12	R1/4	11	38	42.5	21	23.4	29.4	21	8	51
ATL12-02-□				29.8	34.2			21			
TL12-03-□	12	R3/8	12	39	43.2	21	23.4	29.4	21	10	52
ATL12-03-□				32.5	36.7			21			
TL12-04-□	12	R1/2	15	42	44.3	21	23.4	29.4	21	10	67
ATL12-04-□				36.5	38.8			21			

*D⇒禁油仕様のみ、-□⇒無記入（標準品）とD（禁油仕様）の選択

*テーパねじタイプのL寸法は、ねじ締付け後の参考寸法です。

*価格に変更はありません。

TLL/ATLL ロングエルボ

●現行品 TLL

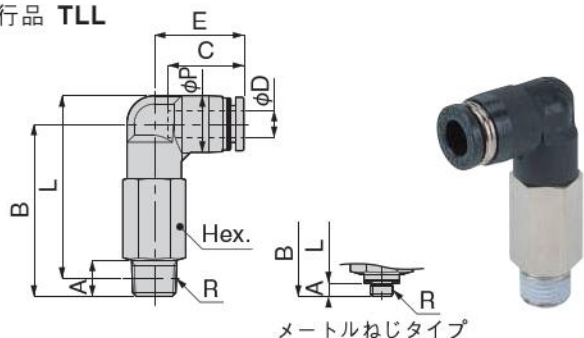

●新形状 ATLL

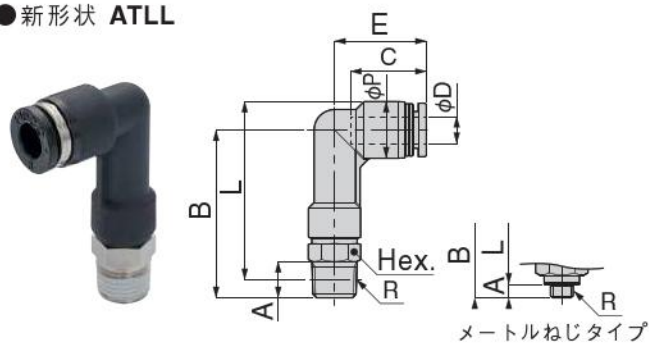

単位：mm

形式	チューブ外径 φD	R	A	B	L	φP	C	E	対辺 Hex.	オリフィス径 (φmm)	質量 (g)
TLL4-M5-D	4	M5×0.8	3	32.3	34.3	10	14.9	18	10	1.8	8.4
ATLL4-M5-D			2.8	28	30.2			18.7	8	2.4	6.4
TLL4-01-D	4	R1/8	8	35.3	36.3	10	14.9	18	10	2.8	17
ATLL4-01-D				34	35			18.7			11
TLL6-01-D	6	R1/8	8	38	40.3	12.5	16.8	19.8	12	4.3	26
ATLL6-01-D				37	39.3		17	20.3			10
TLL6-02-□	6	R1/4	11	41	41.2	12.5	16.8	19.8	14	4.3	39
ATLL6-02-□				42.5	42.7		17	21.8			20
TLL6-03-□	6	R3/8	12	43.3	43.2	12.5	16.8	19.8	17	4.3	62
ATLL6-03-□				46	45.9		17	23.8			33
TLL8-01-□	8	R1/8	8	43.5	46.8	14.5	18.1	22.7	14	6	37
ATLL8-01-□				40.5	43.8				12		16
TLL8-02-□	8	R1/4	11	46.5	47.7	14.5	18.1	22.7	14	6	43
ATLL8-02-□				44.5	45.7						23.7
TLL8-03-□	8	R3/8	12	48.3	49.2	14.5	18.1	22.7	17	6	66
ATLL8-03-□				47.5	48.4						24.7
TLL10-02-□	10	R1/4	11	54.5	57.2	17.5	20.2	26.2	17	8	65
ATLL10-02-□				48	50.7			26	14		26
TLL10-03-□	10	R3/8	12	55.5	57.9	17.5	20.2	26.2	17	8	74
ATLL10-03-□				51.5	53.9			27			8.3
TLL10-04-□	10	R1/2	15	60	60.6	17.5	20.2	26.2	21	8	121
ATLL10-04-□				55.5	56.1			27			8.3
TLL12-02-□	12	R1/4	11	60	64.5	21	23.4	29.4	21	8	112
ATLL12-02-□				52.8	57.2			29	14		30
TLL12-03-□	12	R3/8	12	61	65.2	21	23.4	29.4	21	10	107
ATLL12-03-□				55.5	59.7			29.7	17		42
TLL12-04-□	12	R1/2	15	64	66.3	21	23.4	29.4	21	10	123
ATLL12-04-□				59.5	61.8			29.7			10.3

*D⇒禁油仕様のみ、-□⇒無記入（標準品）とD（禁油仕様）の選択

*テーパねじタイプのL寸法は、ねじ締付け後の参考寸法です。

*価格に変更はありません。

TT/ATT ティー

●現行品 TT

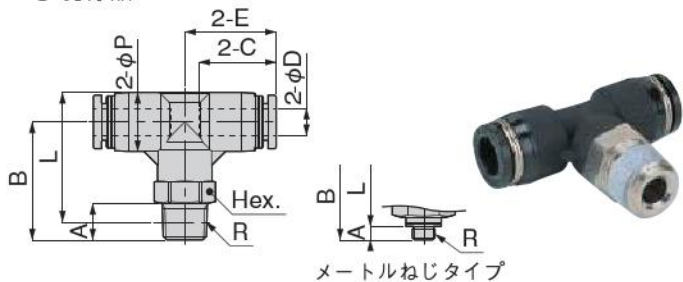

●新形状 ATT

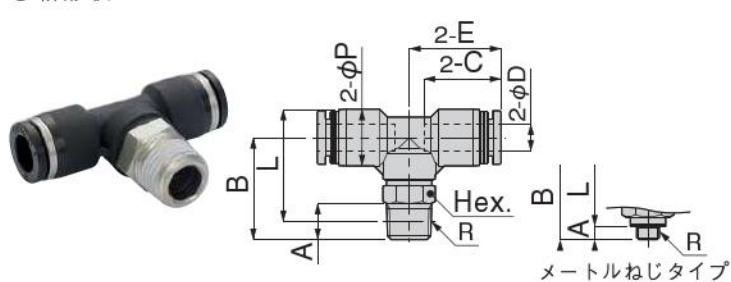

単位：mm

形式	チューブ外径 φD	R	A	B	L	φP	C	E	対辺 Hex.	オリフィス径 (φmm)	質量 (g)
TT4-M5-D	4	M5×0.8	3	20.2	22.2	10	14.9	16.9	10	1.8	11
ATT4-M5-D			2.8	16	18.2			17.7			
TT4-M6-D	4	M6×1	4	21.2	22.2	10	14.9	16.9	10	2.4	11
ATT4-M6-D			3.8	20	21.2			18.7			
TT4-01-D	4	R1/8	8	23.2	24.2	10	14.9	16.9	10	2.8	14
ATT4-01-D				22	23			18.7			13
TT4-02-□	4	R1/4	11	26.2	25.2	10	14.9	16.9	14	2.8	23
ATT4-02-□				29	28			20.7			20
TT6-M5-D	6	M5×0.8	3	23	26.5	13	17	20.15	12	1.8	16
ATT6-M5-D			2.8	19.5	23			12.5			
TT6-M6-D	6	M6×1	4	24	26.5	13	17	20.15	12	3	16
ATT6-M6-D			3.8	20.5	23			12.5			
TT6-01-D	6	R1/8	8	26	28.5	13	17	20.15	12	4.3	18
ATT6-01-D				22.5	24.8			12.5			20.25
TT6-02-□	6	R1/4	11	29	29.5	13	17	20.15	14	4.3	26
ATT6-02-□				28	28.2			12.5			21.75
TT6-03-□	6	R3/8	12	30.8	31	13	17	20.15	17	4.3	39
ATT6-03-□				31.5	31.4			12.5			23.75
TT8-01-□	8	R1/8	8	26.3	29.8	15	18.1	22.4	14	5.8	23
ATT8-01-□				24	27.3			14.5			22.7
TT8-02-□	8	R1/4	11	29.3	30.8	15	18.1	22.4	14	5.8	29
ATT8-02-□				28	29.2			14.5			23.7
TT8-03-□	8	R3/8	12	31.1	32.3	15	18.1	22.4	17	5.8	42
ATT8-03-□				31	31.9			14.5			24.7
TT10-02-□	10	R1/4	11	36	38.7	17.5	20.2	25.2	17	8	42
ATT10-02-□				28.5	31.2						26
TT10-03-□	10	R3/8	12	37	39.4	17.5	20.2	25.2	17	8	50
ATT10-03-□				32	34.4						27
TT10-04-□	10	R1/2	15	40	40.6	17.5	20.2	25.2	21	8	72
ATT10-04-□				36	36.6						27.5
TT12-02-□	12	R1/4	11	38	42.5	21	22.9	28.4	21	8	61
ATT12-02-□				29.8	34.2						23.4
TT12-03-□	12	R3/8	12	39	43.2	21	22.9	28.4	21	10	62
ATT12-03-□				32.5	36.7						23.4
TT12-04-□	12	R1/2	15	42	44.3	21	22.9	28.4	21	10	78
ATT12-04-□				36.5	38.8						23.4

*D ⇒禁油仕様のみ、-□⇒無記入（標準品）とD（禁油仕様）の選択

*テーパねじタイプのL寸法は、ねじ締付け後の参考寸法です。

*価格に変更はありません。

TB/ATB ブランチティー

●現行品 TB

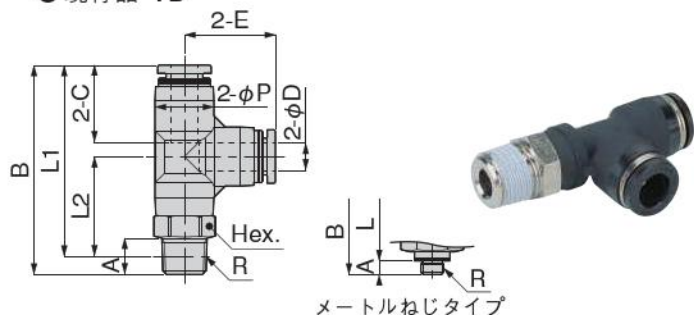

●新形状 ATB

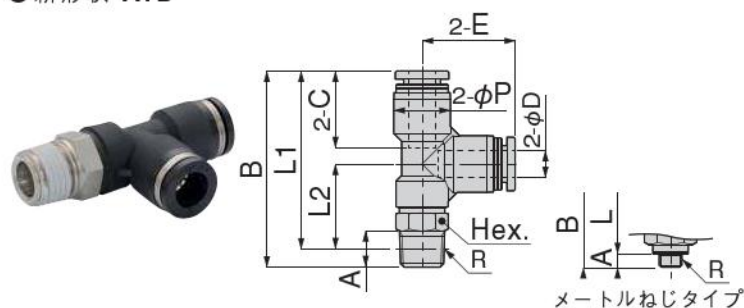

単位：mm

形式	チューブ外径 φD	R	A	B	L1	L2	φP	C	E	対辺 Hex.	オリフィス径 (φmm)	質量 (g)
TB4-M5-D	4	M5×0.8	3	37.1	34.1	17.2	10	14.9	16.9	10	1.8	11
ATB4-M5-D			2.8	33.7	30.9	13.7			17.2	8	2.4	7.8
TB4-M6-D	4	M6×1	4	38.1	34.1	17.2	10	14.9	16.9	10	2.4	11
ATB4-M6-D			3.8	38.2	34.4				17.2			
TB4-01-D	4	R1/8	8	40.1	36.1	19.2	10	14.9	16.9	10	2.8	14
ATB4-01-D				40.2	36.2	19			17.2			13
TB4-02-□	4	R1/4	11	43.1	37.1	20.2	10	14.9	16.9	14	2.8	23
ATB4-02-□				46.2	40.2	23			19.2			20
TB6-M5-D	6	M5×0.8	3	43.2	40.2	20	13	17	20.1	12	1.8	16
ATB6-M5-D				2.8	40.3	37.5			17			
TB6-M6-D	6	M6×1	4	44.2	40.2	20	13	17	20.1	12	3	17
ATB6-M6-D				3.8	41.3	37.5			17			
TB6-01-D	6	R1/8	8	46.2	42.2	22	13	17	20.1	12	4.3	18
ATB6-01-D				43.3	39.3	18.8			12.5			20.5
TB6-02-□	6	R1/4	11	49.2	43.1	23	13	17	20.1	14	4.3	26
ATB6-02-□				48.8	42.7	22.2			12.5			20.5
TB6-03-□	6	R3/8	12	51	44.6	24.5	13	17	20.1	17	4.3	39
ATB6-03-□				52	45.7	25.2			12.5			21.5
TB8-01-□	8	R1/8	8	50.4	46.4	24.2	15	18.1	22.2	14	6	23
ATB8-01-□				46.9	42.9	20			14.5			22.9
TB8-02-□	8	R1/4	11	53.4	47.4	25.2	15	18.1	22.2	14	6	29
ATB8-02-□				51.7	45.7	22.8			14.5			22.9
TB8-03-□	8	R3/8	12	55.2	48.9	26.7	15	18.1	22.2	17	6	42
ATB8-03-□				55.4	49.1	26.2			14.5			22.9
TB10-02-□	10	R1/4	11	61.2	55.2	30	17.5	20.2	25.2	17	8	42
ATB10-02-□				54.7	48.7	22.5			26.2			14
TB10-03-□	10	R3/8	12	62.2	55.9	30.7	17.5	20.2	25.2	17	8	50
ATB10-03-□				58.2	51.9	25.7			26.2			17
TB10-04-□	10	R1/2	15	65.2	57	31.8	17.5	20.2	25.2	21	8	72
ATB10-04-□				62.2	54	27.8			27.3			17
TB12-02-□	12	R1/4	11	66.6	60.6	32.2	21	22.9	28.2	21	8	62
ATB12-02-□				60.3	54.2	23.7			23.4			30
TB12-03-□	12	R3/8	12	67.6	61.3	32.9	21	22.9	28.2	21	10	78
ATB12-03-□				63.5	57.2	26.7			23.4			30.5
TB12-04-□	12	R1/2	15	70.6	62.4	34	21	22.9	28.2	21	10	78
ATB12-04-□				67.5	59.3	28.8			23.4			30.7

*D ⇒禁油仕様のみ、-□⇒無記入(標準品)とD(禁油仕様)の選択

*テーパねじタイプのL寸法は、ねじ締付け後の参考寸法です。

*価格に変更はありません。

TBY/ATBY ブランチワイ

●現行品 **TBY**

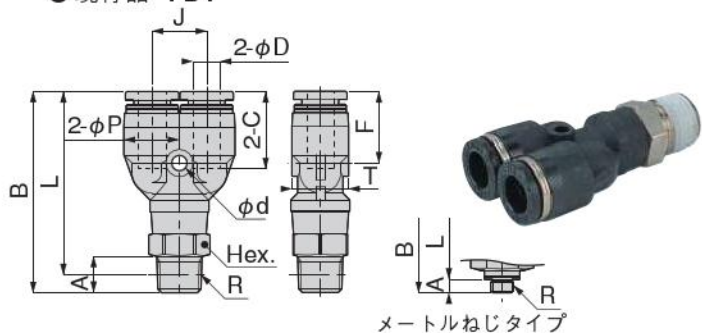

●新形状 **ATBY**

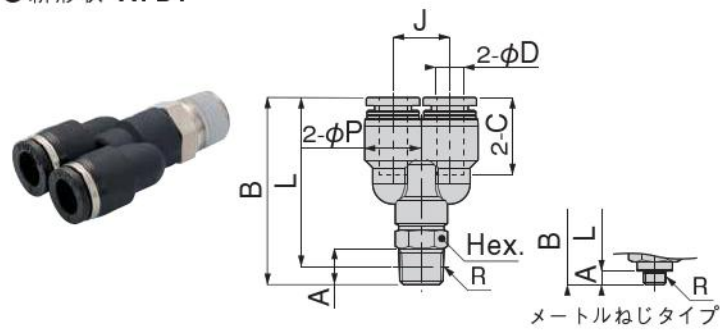

単位：mm

形式	チューブ外径 φD	R	A	B	L	φP	C	J	φd	F	T	対辺 Hex.	リフイス径 (φmm)	質量 (g)
TBY4-M5-□	4	M5×0.8	3	37.6	34.6	10	14.9	11	3.2	14.1	10.4	10	1.8	11
ATBY4-M5-□			2.8	32.9	30.1			10.3	-	-	8			
TBY4-01-□	4	R1/8	8	40.6	36.6	10	14.9	11	3.2	14.1	10.4	10	2.7	14
ATBY4-01-□				38.4	34.4			10.3	-	-	2.8			
TBY4-02-□	4	R1/4	11	43.6	37.6	10	14.9	11	3.2	14.1	10.4	14	2.7	23
ATBY4-02-□				43.4	37.4			10.3	-	-	2.8			
TBY6-M5-□	6	M5×0.8	3	41.4	38.4	12.5	17	12	3.4	15.8	13.5	12	1.8	16
ATBY6-M5-□			2.8	38.3	35.5			12.5	-	-	10			
TBY6-M6-□	6	M6×1	4	42.4	38.4	12.5	17	12	3.4	15.8	13.5	12	3	17
ATBY6-M6-□			3.8	39.3	35.5			12.5	-	-	10			
TBY6-01-□	6	R1/8	8	44.4	40.4	12.5	17	12	3.4	15.8	13.5	12	4.4	18
ATBY6-01-□				41.3	37.3			12.5	-	-	10			
TBY6-02-□	6	R1/4	11	47.4	41.3	12.5	17	12	3.4	15.8	13.5	14	4.4	26
ATBY6-02-□				48.3	42.2			12.5	-	-	4.3			
TBY6-03-□	6	R3/8	12	49.2	42.8	12.5	17	12	3.4	15.8	13.5	17	4.4	40
ATBY6-03-□				51.3	44.9			12.5	-	-	4.3			
TBY8-01-□	8	R1/8	8	48.7	44.7	14.5	18.1	14	3.4	17.2	15.1	14	5.9	24
ATBY8-01-□				46.1	42.1			14.5	-	-	12			
TBY8-02-□	8	R1/4	11	51.7	45.7	14.5	18.1	14	3.4	17.2	15.1	14	5.9	29
ATBY8-02-□				49.3	43.3			14.5	-	-	14			
TBY8-03-□	8	R3/8	12	53.5	47.2	14.5	18.1	14	3.4	17.2	15.1	17	5.9	43
ATBY8-03-□				52.5	46.2			14.5	-	-	17			
TBY10-02-□	10	R1/4	11	58.3	52.3	18	20.7	18	4.5	19.5	18	17	6.7	44
ATBY10-02-□				53.6	47.6			17.5	20.2	17.5	-			
TBY10-03-□	10	R3/8	12	59.3	53	18	20.7	18	4.5	19.5	18	17	6.7	52
ATBY10-03-□				56.7	50.4			17.5	20.2	17.5	-			
TBY10-04-□	10	R1/2	15	62.3	54.1	18	20.7	18	4.5	19.5	18	21	6.7	74
ATBY10-04-□				60.2	52			17.5	20.2	17.5	-			
TBY12-02-□	12	R1/4	11	63.5	57.5	21	23.4	20	4.2	22.2	21	21	8	64
ATBY12-02-□				58.6	52.6			21	23.4	21	-			
TBY12-03-□	12	R3/8	12	64.5	58.2	21	23.4	20	4.2	22.2	21	21	8	65
ATBY12-03-□				60.6	54.3			21	23.4	21	-			
TBY12-04-□	12	R1/2	15	67.5	59.3	21	23.4	20	4.2	22.2	21	21	8	81
ATBY12-04-□				64.7	56.5			21	23.4	21	-			

*-□⇒無記入(標準品)とD(禁油仕様)の選択
 *テーパねじタイプのL寸法は、ねじ締付け後の参考寸法です。
 *価格に変更はありません。

TBLY/ATBLY ブランチエルボワイ

● 現行品 TBLY

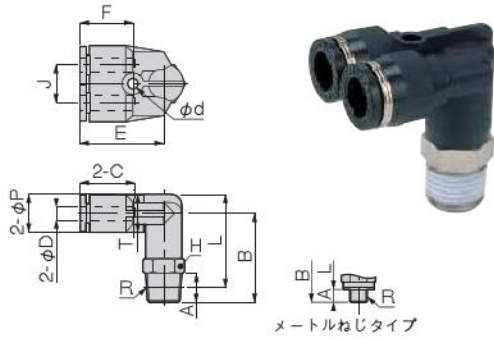

● 新形状 ATBLY

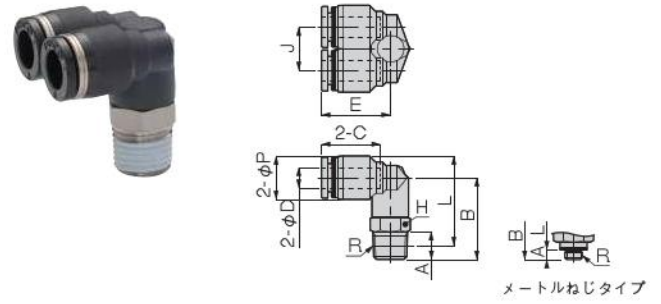

は、新形式（新形状）で寸法が変更された部分です。

単位：mm

形式	ファブ外径 φD	R	A	B	L	φP	C	J	E	対辺 Hex.	φd	F	T	リフス径 (φmm)	質量 (g)
TBLY4-M5-□	4	M5×0.8	3	21.7	23.7	10	14.9	11	22.7	10	3.2	14.2	10	1.8	12
ATBLY4-M5-□			2.8	20	22.2			10.3	18.2		—	—	—	2.4	11
TBLY4-M6-□	4	M6×1	4	22.7	23.7	10	14.9	11	22.7	10	3.2	14.2	10	2.8	12
ATBLY4-M6-□			3.8	21	22.2			10.3	18.2		—	—	—	3	11
TBLY4-01-□	4	R1/8	8	24.7	25.7	10	14.9	11	22.7	10	3.2	14.2	10	2.8	15
ATBLY4-01-□			23	24	10.3			18.2	—		—	—	3.9	13	
TBLY4-02-□	4	R1/4	11	27.7	26.7	10	14.9	11	22.7	14	3.2	14.2	10	2.8	24
ATBLY4-02-□			27	26	10.3			19.2	—		—	—	3.9	20	
TBLY6-M5-□	6	M5×0.8	3	25	28.3	12.5	17	12	26.2	12	4.2	15.5	12.5	1.8	17
ATBLY6-M5-□			2.8	20.5	24			12.5	19.8		10	—	—	—	2.4
TBLY6-M6-□	6	M6×1	4	26	28.3	12.5	17	12	26.2	12	4.2	15.5	12.5	3	18
ATBLY6-M6-□			3.8	21.5	24			12.5	19.8		10	—	—		—
TBLY6-01-□	6	R1/8	8	28	30.3	12.5	17	12	26.2	12	4.2	15.5	12.5	4	19
ATBLY6-01-□			23.5	25.8	12.5			19.8	10		—	—	—	4.2	15
TBLY6-02-□	6	R1/4	11	31	31.2	12.5	17	12	26.2	14	4.2	15.5	12.5	4	27
ATBLY6-02-□			29	29.2	12.5			21.8	—		—	—	5.3	22	
TBLY6-03-□	6	R3/8	12	32.8	32.7	12.5	17	12	26.2	17	4.2	15.5	12.5	4	40
ATBLY6-03-□			31.5	31.4	12.5			23.8	—		—	—	5.3	34	
TBLY8-01-□	8	R1/8	8	31	34.3	14.5	18.1	14	29.4	14	4.2	16.9	14.5	4.1	25
ATBLY8-01-□			25	28.3	14.5			22.7	12		—	—	—	5.7	20
TBLY8-02-□	8	R1/4	11	34	35.2	14.5	18.1	14	29.4	14	4.2	16.9	14.5	4.1	31
ATBLY8-02-□			29	30.2	14.5			23.7	—		—	—	7.3	25	
TBLY8-03-□	8	R3/8	12	35.8	36.7	14.5	18.1	14	29.4	17	4.2	16.9	14.5	4.1	44
ATBLY8-03-□			32	32.9	14.5			24.7	—		—	—	7.3	37	
TBLY10-02-□	10	R1/4	11	37	39.7	17.5	20.2	18	33.5	17	4.2	18.5	17.5	7.5	46
ATBLY10-02-□			29.5	32.2	17.5			26	14		—	—	—	8	32
TBLY10-03-□	10	R3/8	12	38	40.4	17.5	20.2	18	33.5	17	4.2	18.5	17.5	7.5	54
ATBLY10-03-□			32.5	34.9	17.5			27	—		—	—	9.2	43	
TBLY10-04-□	10	R1/2	15	41	41.6	17.5	20.2	18	33.5	21	4.2	18.5	17.5	7.5	76
ATBLY10-04-□			37	37.6	17.5			28	—		—	—	9.2	66	
TBLY12-02-□	12	R1/4	11	41.2	45.7	21	23.4	20	35.2	21	4.2	20.4	21	8	67
ATBLY12-02-□			29.5	34	21			28.2	14		—	—	—		39
TBLY12-03-□	12	R3/8	12	42.2	46.4	21	23.4	20	35.2	21	4.2	20.4	21	9.8	68
ATBLY12-03-□			33.5	37.7	21			29.2	17		—	—	—	9.7	51
TBLY12-04-□	12	R1/2	15	45.2	47.5	21	23.4	20	35.2	21	4.2	20.4	21	9.8	83
ATBLY12-04-□			38	40.3	21			30.2	—		—	—	10.6	74	

* □⇒無記入（標準品）とD（禁油仕様）の選択

* テーパねじタイプのL寸法は、ねじ締付け後の参考寸法です。

* 価格に変更はありません。

TBW/ATBW ブランチ2重ワイ

● 現行品 TBW

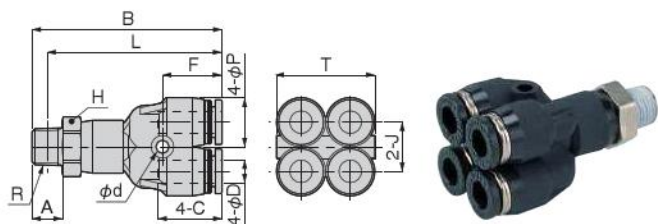

● 新形状 ATBW

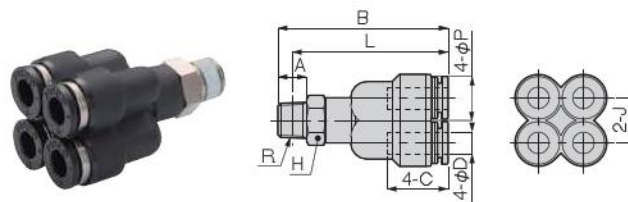

■ は、新形式（新形状）で寸法が変更された部分です。

単位：mm

形式	フープ外径 ϕD	R	A	B	L	ϕP	C	J	対辺 Hex.	ϕd	F	T	リフス径 (ϕmm)	質量 (g)
TBW4-01-□	4	R1/8	8	45.7	41.7	10.5	14.9	10	12	3.2	14.2	20.5	2.1	22
ATBW4-01-□				38.9	34.9			10.3		—	—	—	2.6	16
TBW4-02-□	4	R1/4	11	48.7	42.7	10.5	14.9	10	14	3.2	14.2	20.5	2.1	30
ATBW4-02-□				42.4	36.4			10.3		—	—	—	2.6	21
TBW6-01-□	6	R1/8	8	50.3	46.3	13	17	13	14	3.5	15.8	26	4.3	29
ATBW6-01-□				47.2	43.2			12.5		12	—	—	—	5.2

* □⇒無記入（標準品）とD（禁油仕様）の選択

* テーパねじタイプのL寸法は、ねじ締付け後の参考寸法です。

* 価格に変更はありません。

TBE/ATBE ブランチトリプル

● 現行品 TBE

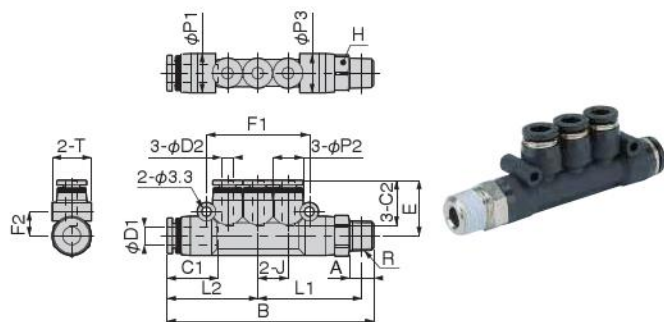

● 新形状 ATBE

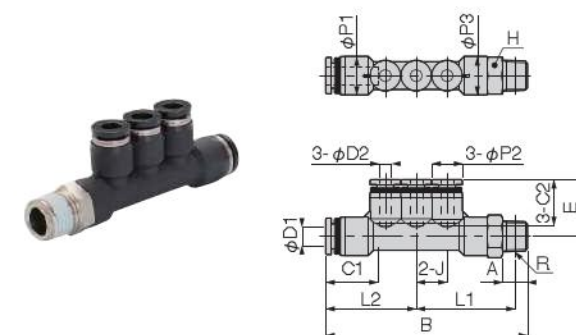

■ は、新形式（新形状）で寸法が変更された部分です。

単位：mm

形式	フープ外径 ϕD1	フープ外径 ϕD2	R	A	B	E	L1	L2	J	ϕP1	ϕP2	ϕP3	C1	C2	F1	F2	対辺 Hex.	T	リフス径 (ϕmm)	質量 (g)
TBE6-4-01-□	6	4	R1/8	8	68.4	18.4	34.3	30.1	10	13	10	13	17	14.9	34	8	12	13	3	24
ATBE6-4-01-□					65.4	32.1	29.3	12.5		12.5	—	—			—	—		—	21	
TBE8-4-02-□	8	4	R1/4	11	73.7	19.2	36.5	31.2	10	15	10	15	18.1	14.9	34	9.2	14	15	3	34
ATBE8-4-02-□					69.2	32	14.5	14.5		—	—	—			—	—		28		
TBE8-6-02-□	8	6	R1/4	11	80.7	21.3	40	34.7	12	15	13	15	18.1	17	40.2	9	14	15	4.6	37
ATBE8-6-02-□					76.9	36.5	34.4	12.5		14.5	12.5	14.5			—	—		—	35	
TBE10-8-03-□	10	8	R3/8	12	93	23.7	46.7	40	14	17.5	15	17.5	20.7	18.1	46.2	10.5	17	17.5	7	60
ATBE10-8-03-□					87.8	41.5	40	14.5		17.5	14.5	18			20.2	—		—	—	6.7

* □⇒無記入（標準品）とD（禁油仕様）の選択

* テーパねじタイプのL1寸法は、ねじ締付け後の参考寸法です。

* 価格に変更はありません。

TBEW/ATBEW ブランチトリプルダブル

● 現行品 TBEW

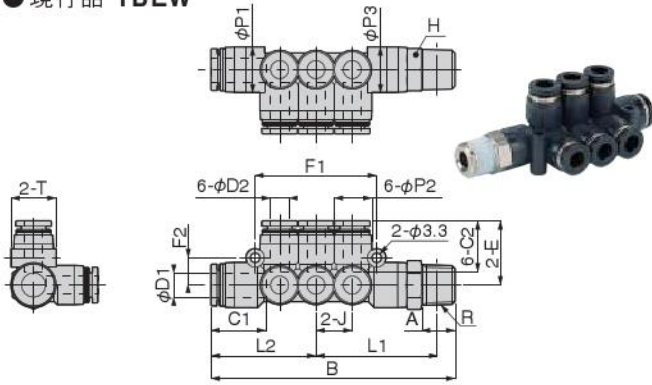

● 新形状 ATBEW

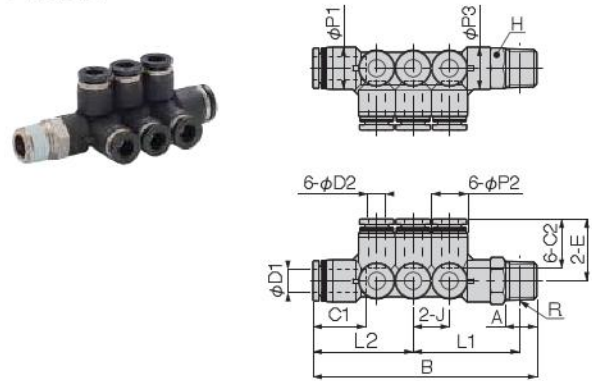

は、新形式（新形状）で寸法が変更された部分です。

単位：mm

形式	φD1	φD2	R	A	B	E	L1	L2	J	φP1	φP2	φP3	C1	C2	F1	F2	対辺 Hex.	T	ねじ径 (φmm)	質量 (g)
TBEW8-4-02-□	8	4	R1/4	11	80.7	20.7	40	34.7	12	15	13	15	18.1	14.9	40.2	9	14	15	3	45
ATBEW8-4-02-□					69.2	19.2	32	31.2	10	14.5	10	14.5			—	—		—		32
TBEW8-4-03-□	8	4	R3/8	12	82.5	20.7	41.5	34.7	12	15	13	15	18.1	14.9	40.2	9	17	15	3	58
ATBEW8-4-03-□					72.2	19.2	34.7	31.2	10	14.5	10	18			—	—		—		46
TBEW8-6-02-□	8	6	R1/4	11	80.7		40	34.7	12	15	13	15	18.1	17	40.2	9	14	15	4.6	47
ATBEW8-6-02-□					76.9	21.3	36.5	34.4	12.5	14.5	12.5	14.5			—	—		—		41
TBEW8-6-03-□	8	6	R3/8	12	82.5		41.5	34.7	12	15	13	15	18.1	17	40.2	9	17	15	4.6	60
ATBEW8-6-03-□					80.7	21.3	39.9	34.4	12.5	14.5	12.5	18			—	—		—		52
TBEW10-6-03-□	10	6	R3/8	12	93	23.8	46.7	40	14	17.5	15	17.5	20.2	17	46.2	10.5	17	17.5	4.6	70
ATBEW10-6-03-□					81.5	22.3	38.2	37	12.5		12.5	18			—	—		—		56
TBEW10-6-04-□	10	6	R1/2	15	96	23.8	47.8	40	14	17.5	15	17.5	20.2	17	46.2	10.5	21	17.5	4.6	93
ATBEW10-6-04-□					85.5	22.3	40.3	37	12.5		12.5	20			—	—		—		78
TBEW10-8-03-□	10	8	R3/8	12	93		46.7		14	17.5	15	17.5	20.2	18.1	46.2	10.5	17	17.5	7	74
ATBEW10-8-03-□					87.8	23.7	41.5	40	14.5		14.5	18			—	—		—	6.7	65
TBEW10-8-04-□	10	8	R1/2	15	96		47.8		14	17.5	15	17.5	20.2	18.1	46.2	10.5	21	17.5	7	96
ATBEW10-8-04-□					91.8	23.7	43.6	40	14.5		14.5	20			—	—		—	6.7	87

* □⇒無記入（標準品）と D（禁油仕様）の選択

* テーパーねじタイプの L1 寸法は、ねじ締付け後の参考寸法です。

* 価格に変更はありません。

TBZ/ATBZ ブランチテトラ

●現行品 **TBZ**

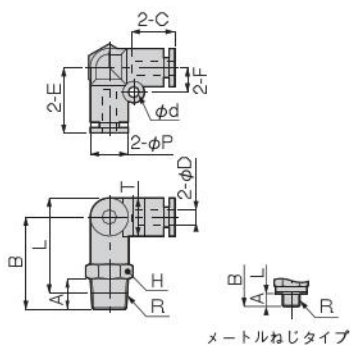

●新形状 **ATBZ**

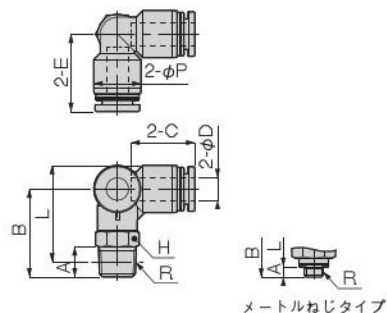

■は、新形式（新形状）で寸法が変更された部分です。

単位：mm

形式	フューブ外径 φD	R	A	B	L	φP	C	E	対辺 Hex.	φd	F	T	オリフィス径 (φmm)	質量 (g)
TBZ4-M5-□	4	M5×0.8	3	21.7	23.7	10	14.9	16.9	10	3.2	6.5	10	1.8	11
ATBZ4-M5-□			2.8	20.3	22.5			18.2		—	—	—		
TBZ4-M6-□	4	M6×1	4	22.7	23.7	10	14.9	16.9	10	3.2	6.5	10	3	11
ATBZ4-M6-□			3.8	21.3	22.5			18.2		—	—	—		
TBZ4-01-□	4	R1/8	8	24.7	25.7	10	14.9	16.9	10	3.2	6.5	10	3	14
ATBZ4-01-□			23.3	24.3	18.2			—		—	—	—		13
TBZ4-02-□	4	R1/4	11	27.7	26.7	10	14.9	16.9	14	3.2	6.5	10	3	23
ATBZ4-02-□			29	28	20.7			—		—	—	—		20
TBZ6-M5-□	6	M5×0.8	3	25.3	28.6	12.5	17	20.1	12	4.2	8	12.5	1.8	17
ATBZ6-M5-□			2.8	20.3	23.7			20.5		10	—	—		—
TBZ6-M6-□	6	M6×1	4	26.3	28.6	12.5	17	20.1	12	4.2	8	12.5	3	17
ATBZ6-M6-□			3.8	21.3	23.7			20.5		10	—	—		—
TBZ6-01-□	6	R1/8	8	28.3	30.6	12.5	17	20.1	12	4.2	8	12.5	4.6	18
ATBZ6-01-□			23.3	25.5	20.5			10		—	—	—		15
TBZ6-02-□	6	R1/4	11	31.3	31.5	12.5	17	20.1	14	4.2	8	12.5	4.6	26
ATBZ6-02-□			28	28.2	21.8			14		—	—	—		22
TBZ6-03-□	6	R3/8	12	33.1	33	12.5	17	20.1	17	4.2	8	12.5	4.6	39
ATBZ6-03-□			31.5	31.4	23.8			17		—	—	—		33
TBZ8-01-□	8	R1/8	8	30.4	33.7	14.5	18.1	22.1	14	4.2	10	14.5	6	24
ATBZ8-01-□			25	28.3	22.7			12		—	—	—		20
TBZ8-02-□	8	R1/4	11	33.4	34.6	14.5	18.1	22.1	14	4.2	10	14.5	6	30
ATBZ8-02-□			29	30.2	23.7			14		—	—	—		6.7
TBZ8-03-□	8	R3/8	12	35.2	36.1	14.5	18.1	22.1	17	4.2	10	14.5	6	42
ATBZ8-03-□			32	32.9	24.7			17		—	—	—		6.7
TBZ10-02-□	10	R1/4	11	38.2	40.9	17.5	20.2	26.2	17	4.2	12	17.5	8	44
ATBZ10-02-□			29.4	32.1	26			14		—	—	—		31
TBZ10-03-□	10	R3/8	12	39.2	41.6	17.5	20.2	26.2	17	4.2	12	17.5	8	52
ATBZ10-03-□			33	35.4	27			17		—	—	—		8.3
TBZ10-04-□	10	R1/2	15	42.2	42.8	17.5	20.2	26.2	21	4.2	12	17.5	8	74
ATBZ10-04-□			37	37.6	27.5			21		—	—	—		8.3
TBZ12-02-□	12	R1/4	11	41.2	45.7	21	23.4	29.4	21	4.2	14	21	8	64
ATBZ12-02-□			30.8	35.2	30.2			14		—	—	—		37
TBZ12-03-□	12	R3/8	12	42.2	46.4	21	23.4	29.4	21	4.2	14	21	10	65
ATBZ12-03-□			33.5	37.7	30.2			17		—	—	—		49
TBZ12-04-□	12	R1/2	15	45.2	47.5	21	23.4	29.4	21	4.2	14	21	10	81
ATBZ12-04-□			38	40.3	31.2			21		—	—	—		10.3

* □⇒無記入（標準品）とD（禁油仕様）の選択

* テーパねじタイプのL寸法は、ねじ締付け後の参考寸法です。

* 価格に変更はありません。

サプライジョイント

SKR/ASKR 隔壁レデューサ

● 現行品 SKR

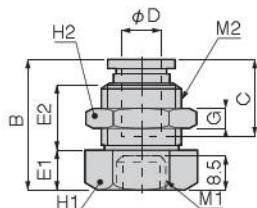

● 新形状 ASKR

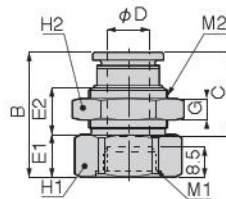

は、新形式（新形状）で寸法が変更された部分です。

単位：mm

形式	チューブ外径 φD	M1	M2	B	E1	E2	C	G	H1	H2	有効断面積 (mm ²)	質量 (g)
SKR8-4	4	M8×1	M12×1	26	8	13.4	14.9	4	14	14	5.6	19
ASKR8-4						11.8						18
SKR8-6	6	M8×1	M14×1	28.1	8	14.9	17	4	17	17	11.5	29
ASKR8-6						13.9						29
SKR12-6	6	M12×1	M14×1	28.1	12	10.9	17	4	17	17	13.2	28
ASKR12-6						9.9						28
SKR12-8	8	M12×1	M16×1	28.9	10	13.4	18.2	4	19	19	27.4	34
ASKR12-8						11.7						33
SKR12-10	10	M12×1	M20×1	32.3	10	16.4	20.7	5	22	24	34.8	60
ASKR12-10						13.7						57
SKR14-8	8	M14×1	M16×1	28.9	12	11.4	18.2	4	19	19	27.7	33
ASKR14-8						9.7						32
SKR14-10	10	M14×1	M20×1	32.3	10	16.4	20.7	5	24	24	41.7	64
ASKR14-10						13.7						60
SKR14-12	12	M14×1	M22×1	34.9	12	17.4	23.3	6	24	27	54.7	78
ASKR14-12						13						74
SKR18-12	12	M18×1	M22×1	34.9	12	17.4	23.3	6	27	27	66.7	83
ASKR18-12						13						79

* 価格に変更はありません。

サプライジョイント（組立例）



新形式による各仕様 形式一覧表

※継手形式、チューブサイズおよびねじサイズの組合せについては下表をご覧ください。

なおNCU仕様について、~~一部のものは標準品がNCU仕様として使用できますので標準品でご注文ください。~~

●下記NCU仕様およびCS仕様の寸法図は、標準品または禁油仕様と同じです。①～⑩ページの寸法図を参照してください。

●形式表

名称	継手 チューブ 外径	ねじサイズ	標準品形式 または禁油仕様	NCU仕様	CS仕様	
ストレート ATS	4	M5×0.8	ATS4-M5-D ATS4-M50-□	— ←	CS-ATS4-M5 CS-ATS4-M50	
		M6×1	ATS4-M6-D	—	CS-ATS4-M6	
		R1/8	ATS4-01-D	NCU-ATS4-01	CS-ATS4-01	
		R1/4	ATS4-02-□	NCU-ATS4-02	CS-ATS4-02	
		R1/8	ATS6-M5-D	—	CS-ATS6-M5	
	6	M6×1	ATS6-M6-D	—	CS-ATS6-M6	
		R1/8	ATS6-01-D	NCU-ATS6-01	CS-ATS6-01	
		R1/4	ATS6-02-□	NCU-ATS6-02	CS-ATS6-02	
		R3/8	ATS6-03-□	NCU-ATS6-03	CS-ATS6-03	
		R1/8	ATS8-01-□	NCU-ATS8-01	CS-ATS8-01	
	8	R1/4	ATS8-02-□	NCU-ATS8-02	CS-ATS8-02	
		R3/8	ATS8-03-□	NCU-ATS8-03	CS-ATS8-03	
		R1/8	ATS10-01-□	NCU-ATS10-01	CS-ATS10-01	
		R1/4	ATS10-02-□	NCU-ATS10-02	CS-ATS10-02	
		R3/8	ATS10-03-□	NCU-ATS10-03	CS-ATS10-03	
	10	R1/2	ATS10-04-□	NCU-ATS10-04	CS-ATS10-04	
		R1/4	ATS12-02-□	NCU-ATS12-02	CS-ATS12-02	
		R3/8	ATS12-03-□	NCU-ATS12-03	CS-ATS12-03	
		R1/2	ATS12-04-□	NCU-ATS12-04	CS-ATS12-04	
		R3/8	ATS16-03-□	NCU-ATS16-03	CS-ATS16-03	
	16	R1/2	ATS16-04-□	NCU-ATS16-04	CS-ATS16-04	
		4	M5×0.8	ATSH4-M5-D	—	CS-ATSH4-M5
			M6×1	ATSH4-M6-D	—	CS-ATSH4-M6
			R1/8	ATSH4-01-D	NCU-ATSH4-01	CS-ATSH4-01
6		M5×0.8	ATSH6-M5-D	—	CS-ATSH6-M5	
	M6×1	ATSH6-M6-D	—	CS-ATSH6-M6		
	R1/8	ATSH6-01-D	NCU-ATSH6-01	CS-ATSH6-01		
	R1/4	ATSH6-02-□	NCU-ATSH6-02	CS-ATSH6-02		
	R1/8	ATSH8-01-□	NCU-ATSH8-01	CS-ATSH8-01		
8	R1/4	ATSH8-02-□	NCU-ATSH8-02	CS-ATSH8-02		
	R3/8	ATSH8-03-□	NCU-ATSH8-03	CS-ATSH8-03		
	R1/8	ATSH10-01-□	NCU-ATSH10-01	CS-ATSH10-01		
	R1/4	ATSH10-02-□	NCU-ATSH10-02	CS-ATSH10-02		
	R3/8	ATSH10-03-□	NCU-ATSH10-03	CS-ATSH10-03		
10	R1/2	ATSH10-04-□	NCU-ATSH10-04	CS-ATSH10-04		
	R1/4	ATSH12-02-□	NCU-ATSH12-02	CS-ATSH12-02		
	R3/8	ATSH12-03-□	NCU-ATSH12-03	CS-ATSH12-03		
	R1/2	ATSH12-04-□	NCU-ATSH12-04	CS-ATSH12-04		
	R3/8	ATSH16-03-□	NCU-ATSH16-03	CS-ATSH16-03		
16	R1/2	ATSH16-04-□	NCU-ATSH16-04	CS-ATSH16-04		
	4	Rc1/8	ATSM4-01-□	←	CS-ATSM4-01	
		Rc1/4	ATSM4-02-□	←	CS-ATSM4-02	
	6	Rc1/8	ATSM6-01-□	←	CS-ATSM6-01	
		Rc1/4	ATSM6-02-□	←	CS-ATSM6-02	
8	Rc1/8	ATSM8-01-□	←	CS-ATSM8-01		
	Rc1/4	ATSM8-02-□	←	CS-ATSM8-02		
	Rc3/8	ATSM8-03-□	←	CS-ATSM8-03		
10	Rc1/4	ATSM10-02-□	←	CS-ATSM10-02		
	Rc3/8	ATSM10-03-□	←	CS-ATSM10-03		
	Rc1/4	ATSM12-02-□	←	CS-ATSM12-02		
12	Rc3/8	ATSM12-03-□	←	CS-ATSM12-03		

名称	継手 チューブ 外径	ねじサイズ	標準品形式 または禁油仕様	NCU仕様	CS仕様	
隔壁 ユニオン AUK	4	—	AUK4-D	—	CS-AUK4	
	6	—	AUK6-D	—	CS-AUK6	
	8	—	AUK8-□	←	CS-AUK8	
	10	—	AUK10-□	←	CS-AUK10	
	12	—	AUK12-□	←	CS-AUK12	
めす隔壁 ユニオン AUKM	4	Rc1/8	AUKM4-01-□	←	CS-AUKM4-01	
		Rc1/8	AUKM6-01-□	←	CS-AUKM6-01	
	6	Rc1/4	AUKM6-02-□	←	CS-AUKM6-02	
		Rc1/8	AUKM8-01-□	←	CS-AUKM8-01	
	8	Rc1/4	AUKM8-02-□	←	CS-AUKM8-02	
		Rc3/8	AUKM8-03-□	←	CS-AUKM8-03	
	10	Rc1/4	AUKM10-02-□	←	CS-AUKM10-02	
		Rc3/8	AUKM10-03-□	←	CS-AUKM10-03	
	12	Rc3/8	AUKM12-03-□	←	CS-AUKM12-03	
		Rc1/2	AUKM12-04-□	←	CS-AUKM12-04	
	エルボ ATL	4	M5×0.8	ATL4-M5-D	—	CS-ATL4-M5
			M6×1	ATL4-M6-D	—	CS-ATL4-M6
R1/8			ATL4-01-D	NCU-ATL4-01	CS-ATL4-01	
R1/4			ATL4-02-□	NCU-ATL4-02	CS-ATL4-02	
6		M5×0.8	ATL6-M5-D	—	CS-ATL6-M5	
		M6×1	ATL6-M6-D	—	CS-ATL6-M6	
		R1/8	ATL6-01-D	NCU-ATL6-01	CS-ATL6-01	
		R1/4	ATL6-02-□	NCU-ATL6-02	CS-ATL6-02	
8		R3/8	ATL6-03-□	NCU-ATL6-03	CS-ATL6-03	
		R1/8	ATL8-01-□	NCU-ATL8-01	CS-ATL8-01	
		R1/4	ATL8-02-□	NCU-ATL8-02	CS-ATL8-02	
		R3/8	ATL8-03-□	NCU-ATL8-03	CS-ATL8-03	
10	R1/8	ATL10-01-□	NCU-ATL10-01	CS-ATL10-01		
	R1/4	ATL10-02-□	NCU-ATL10-02	CS-ATL10-02		
	R3/8	ATL10-03-□	NCU-ATL10-03	CS-ATL10-03		
	R1/2	ATL10-04-□	NCU-ATL10-04	CS-ATL10-04		
12	R1/4	ATL12-02-□	NCU-ATL12-02	CS-ATL12-02		
	R3/8	ATL12-03-□	NCU-ATL12-03	CS-ATL12-03		
	R1/2	ATL12-04-□	NCU-ATL12-04	CS-ATL12-04		
	R1/8	ATLL4-M5-D	—	CS-ATLL4-M5		
4	R1/8	ATLL4-01-D	NCU-ATLL4-01	CS-ATLL4-01		
	R1/8	ATLL6-01-D	NCU-ATLL6-01	CS-ATLL6-01		
	R1/4	ATLL6-02-□	NCU-ATLL6-02	CS-ATLL6-02		
	R3/8	ATLL6-03-□	NCU-ATLL6-03	CS-ATLL6-03		
8	R1/8	ATLL8-01-□	NCU-ATLL8-01	CS-ATLL8-01		
	R1/4	ATLL8-02-□	NCU-ATLL8-02	CS-ATLL8-02		
	R3/8	ATLL8-03-□	NCU-ATLL8-03	CS-ATLL8-03		
	R1/4	ATLL10-02-□	NCU-ATLL10-02	CS-ATLL10-02		
10	R3/8	ATLL10-03-□	NCU-ATLL10-03	CS-ATLL10-03		
	R1/2	ATLL10-04-□	NCU-ATLL10-04	CS-ATLL10-04		
	R1/4	ATLL12-02-□	NCU-ATLL12-02	CS-ATLL12-02		
12	R3/8	ATLL12-03-□	NCU-ATLL12-03	CS-ATLL12-03		
	R1/2	ATLL12-04-□	NCU-ATLL12-04	CS-ATLL12-04		

*-D ⇒禁油仕様、-□⇒無記入（標準品）とD（禁油仕様）の選択

*-D ⇒禁油仕様、-□⇒無記入（標準品）とD（禁油仕様）の選択

新形式による各仕様 形式一覧表

※継手形式、チューブサイズおよびねじサイズの組合せについては下表をご覧ください。

なおNCU仕様について”←”のものは標準品がNCU仕様として使用できますので標準品でご注文ください。

●下記NCU仕様およびCS仕様の寸法図は、標準品または禁油仕様と同じです。①～⑩ページの寸法図を参照してください。

●形式表

名称	継手 チューブ 外径	ねじサイズ	標準品形式 または禁油仕様	NCU仕様	CS仕様	
ティー ATT	4	M5×0.8	ATT4-M5-D	—	CS-ATT4-M5	
		M6×1	ATT4-M6-D	—	CS-ATT4-M6	
		R1/8	ATT4-01-D	NCU-ATT4-01	CS-ATT4-01	
		R1/4	ATT4-02-□	NCU-ATT4-02	CS-ATT4-02	
	6	M5×0.8	ATT6-M5-D	—	CS-ATT6-M5	
		M6×1	ATT6-M6-D	—	CS-ATT6-M6	
		R1/8	ATT6-01-D	NCU-ATT6-01	CS-ATT6-01	
		R1/4	ATT6-02-□	NCU-ATT6-02	CS-ATT6-02	
	8	R3/8	ATT6-03-□	NCU-ATT6-03	CS-ATT6-03	
		R1/8	ATT8-01-□	NCU-ATT8-01	CS-ATT8-01	
		R1/4	ATT8-02-□	NCU-ATT8-02	CS-ATT8-02	
	10	R3/8	ATT8-03-□	NCU-ATT8-03	CS-ATT8-03	
		R1/4	ATT10-02-□	NCU-ATT10-02	CS-ATT10-02	
		R3/8	ATT10-03-□	NCU-ATT10-03	CS-ATT10-03	
	12	R1/2	ATT10-04-□	NCU-ATT10-04	CS-ATT10-04	
		R1/4	ATT12-02-□	NCU-ATT12-02	CS-ATT12-02	
		R3/8	ATT12-03-□	NCU-ATT12-03	CS-ATT12-03	
	ブランチ ティー ATB	4	M5×0.8	ATB4-M5-D	—	CS-ATB4-M5
			M6×1	ATB4-M6-D	—	CS-ATB4-M6
			R1/8	ATB4-01-D	NCU-ATB4-01	CS-ATB4-01
R1/4			ATB4-02-□	NCU-ATB4-02	CS-ATB4-02	
6		M5×0.8	ATB6-M5-D	—	CS-ATB6-M5	
		M6×1	ATB6-M6-D	—	CS-ATB6-M6	
		R1/8	ATB6-01-D	NCU-ATB6-01	CS-ATB6-01	
		R1/4	ATB6-02-□	NCU-ATB6-02	CS-ATB6-02	
8		R3/8	ATB6-03-□	NCU-ATB6-03	CS-ATB6-03	
		R1/8	ATB8-01-□	NCU-ATB8-01	CS-ATB8-01	
		R1/4	ATB8-02-□	NCU-ATB8-02	CS-ATB8-02	
10		R3/8	ATB8-03-□	NCU-ATB8-03	CS-ATB8-03	
		R1/4	ATB10-02-□	NCU-ATB10-02	CS-ATB10-02	
		R3/8	ATB10-03-□	NCU-ATB10-03	CS-ATB10-03	
12		R1/2	ATB10-04-□	NCU-ATB10-04	CS-ATB10-04	
		R1/4	ATB12-02-□	NCU-ATB12-02	CS-ATB12-02	
		R3/8	ATB12-03-□	NCU-ATB12-03	CS-ATB12-03	
ブランチ ワイ ATBY		4	M5×0.8	ATBY4-M5-□	←	CS-ATBY4-M5
			R1/8	ATBY4-01-□	NCU-ATBY4-01	CS-ATBY4-01
			R1/4	ATBY4-02-□	NCU-ATBY4-02	CS-ATBY4-02
	6	M5×0.8	ATBY6-M5-□	←	CS-ATBY6-M5	
		M6×1	ATBY6-M6-□	←	CS-ATBY6-M6	
		R1/8	ATBY6-01-□	NCU-ATBY6-01	CS-ATBY6-01	
		R1/4	ATBY6-02-□	NCU-ATBY6-02	CS-ATBY6-02	
	8	R3/8	ATBY6-03-□	NCU-ATBY6-03	CS-ATBY6-03	
		R1/8	ATBY8-01-□	NCU-ATBY8-01	CS-ATBY8-01	
		R1/4	ATBY8-02-□	NCU-ATBY8-02	CS-ATBY8-02	
	10	R3/8	ATBY8-03-□	NCU-ATBY8-03	CS-ATBY8-03	
		R1/4	ATBY10-02-□	NCU-ATBY10-02	CS-ATBY10-02	
		R3/8	ATBY10-03-□	NCU-ATBY10-03	CS-ATBY10-03	
	12	R1/2	ATBY10-04-□	NCU-ATBY10-04	CS-ATBY10-04	
		R1/4	ATBY12-02-□	NCU-ATBY12-02	CS-ATBY12-02	
		R3/8	ATBY12-03-□	NCU-ATBY12-03	CS-ATBY12-03	
	R1/2	ATBY12-04-□	NCU-ATBY12-04	CS-ATBY12-04		

*-D ⇒禁油仕様、-□⇒無記入（標準品）とD（禁油仕様）の選択

新形式による各仕様 形式一覧表

※継手形式、チューブサイズおよびねじサイズの組合せについては下表をご覧ください。

なおNCU仕様について“←”のものは標準品がNCU仕様として使用できますので標準品でご注文ください。

●下記NCU仕様およびCS仕様の寸法図は、標準品または禁油仕様と同じです。①～⑤ページの寸法図を参照してください。

●クイック継手スタンダードタイプ形式表

名称	規格チューブ 外径	ねじサイズ	標準品形式 または禁油仕様	NCU仕様	CS仕様
ブランチ エルボワイ ATBLY	4	M5×0.8	ATBLY4-M5-□	←	CS-ATBLY4-M5
		M6×1	ATBLY4-M6-□	←	CS-ATBLY4-M6
		R1/8	ATBLY4-01-□	NCU-ATBLY4-01	CS-ATBLY4-01
		R1/4	ATBLY4-02-□	NCU-ATBLY4-02	CS-ATBLY4-02
	6	M5×0.8	ATBLY6-M5-□	←	CS-ATBLY6-M5
		M6×1	ATBLY6-M6-□	←	CS-ATBLY6-M6
		R1/8	ATBLY6-01-□	NCU-ATBLY6-01	CS-ATBLY6-01
		R1/4	ATBLY6-02-□	NCU-ATBLY6-02	CS-ATBLY6-02
	8	R3/8	ATBLY6-03-□	NCU-ATBLY6-03	CS-ATBLY6-03
		R1/8	ATBLY8-01-□	NCU-ATBLY8-01	CS-ATBLY8-01
		R1/4	ATBLY8-02-□	NCU-ATBLY8-02	CS-ATBLY8-02
	10	R3/8	ATBLY8-03-□	NCU-ATBLY8-03	CS-ATBLY8-03
R1/4		ATBLY10-02-□	NCU-ATBLY10-02	CS-ATBLY10-02	
R3/8		ATBLY10-03-□	NCU-ATBLY10-03	CS-ATBLY10-03	
12	R1/2	ATBLY10-04-□	NCU-ATBLY10-04	CS-ATBLY10-04	
	R1/4	ATBLY12-02-□	NCU-ATBLY12-02	CS-ATBLY12-02	
	R3/8	ATBLY12-03-□	NCU-ATBLY12-03	CS-ATBLY12-03	
ブランチ トリプル ATBE	6-4	R1/8	ATBE6-4-01-□	NCU-ATBE6-4-01	CS-ATBE6-4-01
	8-4	R1/4	ATBE8-4-02-□	NCU-ATBE8-4-02	CS-ATBE8-4-02
	8-6	R1/4	ATBE8-6-02-□	NCU-ATBE8-6-02	CS-ATBE8-6-02
	10-8	R3/8	ATBE10-8-03-□	NCU-ATBE10-8-03	CS-ATBE10-8-03
ブランチ トリプル ダブル ATBEW	8-4	R1/4	ATBEW8-4-02-□	NCU-ATBEW8-4-02	CS-ATBEW8-4-02
		R3/8	ATBEW8-4-03-□	NCU-ATBEW8-4-03	CS-ATBEW8-4-03
	8-6	R1/4	ATBEW8-6-02-□	NCU-ATBEW8-6-02	CS-ATBEW8-6-02
		R3/8	ATBEW8-6-03-□	NCU-ATBEW8-6-03	CS-ATBEW8-6-03
	10-6	R3/8	ATBEW10-6-03-□	NCU-ATBEW10-6-03	CS-ATBEW10-6-03
		R1/2	ATBEW10-6-04-□	NCU-ATBEW10-6-04	CS-ATBEW10-6-04
10-8	R3/8	ATBEW10-8-03-□	NCU-ATBEW10-8-03	CS-ATBEW10-8-03	
	R1/2	ATBEW10-8-04-□	NCU-ATBEW10-8-04	CS-ATBEW10-8-04	
ブランチ 2重ワイ ATBW	4	R1/8	ATBW4-01-□	NCU-ATBW4-01	CS-ATBW4-01
	6	R1/4	ATBW4-02-□	NCU-ATBW4-02	CS-ATBW4-02
ブランチ テトラ ATBZ	4	M5×0.8	ATBZ4-M5-□	←	CS-ATBZ4-M5
		M6×1	ATBZ4-M6-□	←	CS-ATBZ4-M6
		R1/8	ATBZ4-01-□	NCU-ATBZ4-01	CS-ATBZ4-01
		R1/4	ATBZ4-02-□	NCU-ATBZ4-02	CS-ATBZ4-02
	6	M5×0.8	ATBZ6-M5-□	←	CS-ATBZ6-M5
		M6×1	ATBZ6-M6-□	←	CS-ATBZ6-M6
		R1/8	ATBZ6-01-□	NCU-ATBZ6-01	CS-ATBZ6-01
		R1/4	ATBZ6-02-□	NCU-ATBZ6-02	CS-ATBZ6-02
	8	R3/8	ATBZ6-03-□	NCU-ATBZ6-03	CS-ATBZ6-03
		R1/8	ATBZ8-01-□	NCU-ATBZ8-01	CS-ATBZ8-01
		R1/4	ATBZ8-02-□	NCU-ATBZ8-02	CS-ATBZ8-02
	10	R3/8	ATBZ8-03-□	NCU-ATBZ8-03	CS-ATBZ8-03
		R1/4	ATBZ10-02-□	NCU-ATBZ10-02	CS-ATBZ10-02
		R3/8	ATBZ10-03-□	NCU-ATBZ10-03	CS-ATBZ10-03
	12	R1/2	ATBZ10-04-□	NCU-ATBZ10-04	CS-ATBZ10-04
		R1/4	ATBZ12-02-□	NCU-ATBZ12-02	CS-ATBZ12-02
R3/8		ATBZ12-03-□	NCU-ATBZ12-03	CS-ATBZ12-03	
		R1/2	ATBZ12-04-□	NCU-ATBZ12-04	CS-ATBZ12-04

□⇒無記入（標準品）とD（禁油仕様）の選択

●サプライジョイント形式表

名称	規格チューブ 外径	ねじサイズ	標準品形式 または禁油仕様	NCU仕様	CS仕様
隔壁 レデュース ASKR	4	M8×1	ASKR8-4	←	CS-ASKR8-4
	6	M8×1	ASKR8-6	←	CS-ASKR8-6
	6	M12×1	ASKR12-6	←	CS-ASKR12-6
	8	M12×1	ASKR12-8	←	CS-ASKR12-8
	10	M12×1	ASKR12-10	←	CS-ASKR12-10
	8	M14×1	ASKR14-8	←	CS-ASKR14-8
	10	M14×1	ASKR14-10	←	CS-ASKR14-10
	12	M14×1	ASKR14-12	←	CS-ASKR14-12
	12	M18×1	ASKR18-12	←	CS-ASKR18-12

●対象機種の締付けトルク(参考値)およびシーロック色、ガスケット材質

ネジ種類	ネジサイズ	締付けトルク (N・m)	シーロック色	ガスケット材質
メートルねじ	M5×0.8	1～1.5	—	SUS304
	M6×1	2～2.7		NBR
管用テーパねじ※	R1/8	4.5～6.5	白 色	—
	R1/4	7～9		
	R3/8	12.5～14.5		
	R1/2	20～22		

※クイック継手管用テーパねじが付属した全製品共通の締付けトルクとなっています。